

MAHLE

Industry

Suction Filter

Pi 160

1. Features

High performance filters for modern hydraulic systems

- Provided for tank mounting
- Compact design
- Minimal pressure drop through optimal flow design
- Visual/electrical/electronic maintenance indicator
- Threaded or flanged connections
- Vacuum gauge serial production
- Quality filters, easy to service
- Quick-lock design and shut off valve
- Equipped with highly efficient Mic, Sm-x or Drg filter elements
- Beta rated elements according to ISO 16889 multipass test
- Elements with high differential pressure stability and dirt holding capacity
- Worldwide distribution



2. Flow rate/pressure drop curve complete filter

190 mm²/s
33 mm²/s

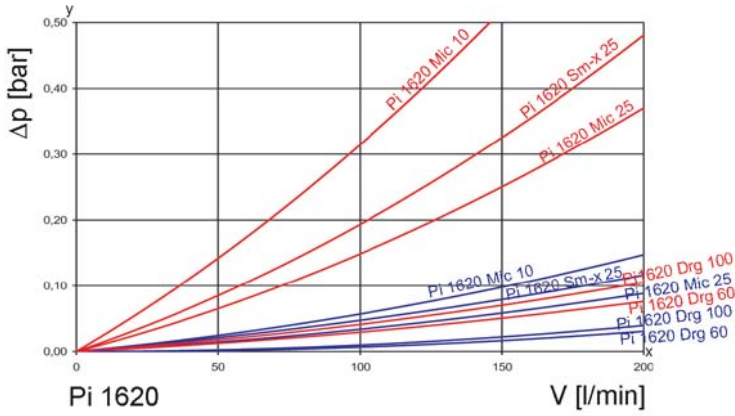
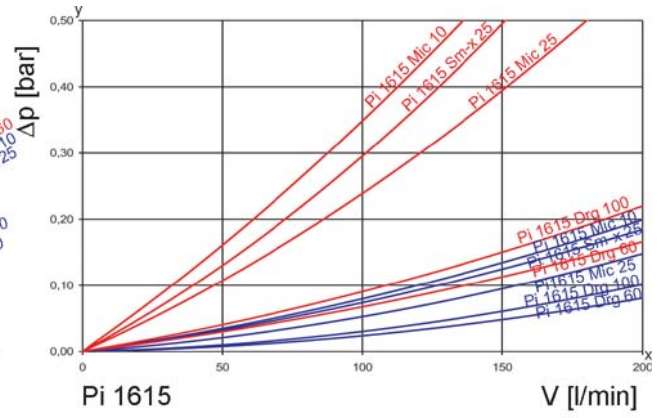
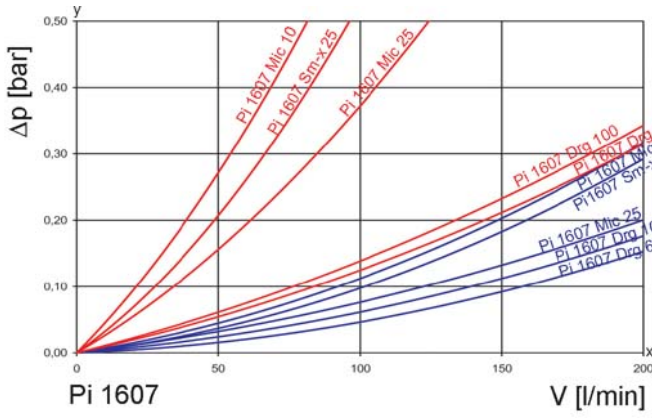

y = differential pressure Δp [bar]
x = flow rate V [l/min]

3. Symbols

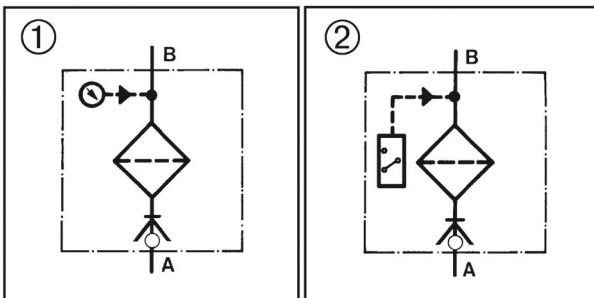

4. Order numbers

Example for ordering filters:

1. Housing design	2. Filter element
V=100 l/min, pressure gauge, Type: Pi 1615-366 Order number: 77774813	Sm-x 25 Type: 852 754 Sm-x 25 Order number: 77730195

4.1 Housing design

Nominal size* NG [l/min] Sm-x + Mic/Drg	Order number	Type	① with vacuum gauge	② with vacuum switch 230V	② with vacuum switch 42V
80/100	77774854	Pi 1607-166			
	77774847	Pi 1607-165			
	77774714	Pi 1607-170			
100/160	77774839	Pi 1615-166			
	77774821	Pi 1615-165			
	77774706	Pi 1615-170			
	77774813	Pi 1615-366			
	77774805	Pi 1615-365			
	77774730	Pi 1615-370			
	77774797	Pi 1615-466			
	77774789	Pi 1615-465			
	77774722	Pi 1615-470			
160/315	77874480	Pi 1620-366			
	77874498	Pi 1620-365			
	77874506	Pi 1620-370			

* at operational viscosity (33 mm²/s); Sm-x 25 (T20(c) y 200) and $\Delta p \leq 0.1$ bar

4.2 Filter element

Nominal size NG [l/min]	Order number	Type	Filter material	Filter surface [cm ²]
80	77729338	852 753 Mic 10	Mic 10	5700
	77729429	852 753 Mic 25	Mic 25	5700
	77729577	852 753 Sm-x 25	Sm-x 25	3750
100	77729387	852 754 Mic 10	Mic 10	15850
	77729445	852 754 Mic 25	Mic 25	15850
	77730195	852 754 Sm-x 25	Sm-x 25	10400
160	77874514	852 821 Mic 10	Mic 10	16750
	77874522	852 821 Mic 25	Mic 25	16750
	77874530	852 821 Sm-x 25	Sm-x 25	11000

4.3 Filter elements wire mesh

Nominal size* NG [l/min]	Order number	Type	Filter material	Filter surface [cm ²]
100	77862345	852 753 Drg 60	Drg 60	2300
	77729486	852 753 Drg 100	Drg 100	2300
160	77862352	852 754 Drg 60	Drg 60	6250
	77729528	852 754 Drg 100	Drg 100	6250
315	77874548	852 821 Drg 60	Drg 60	6650
	77874555	852 821 Drg 100	Drg 100	6650

* at operational viscosity (33 mm²/s) and Drg 100

5. Technical specifications

Design:	suction filter for tank mounting with shut off valve
Installation:	horizontally under oil level or vertically above oil level with optional extension pipe
Temperature range:	-10 °C to +120 °C (other temperature ranges on request)
Filter head material:	GDAL
Filter housing material:	St
Sealing material:	NBR/AL
Indicating range	
vacuum gauge:	-1 bar to 1.5 bar
Pressure setting vacuum switch:	-200 mbar
Electrical data of vacuum switch (PiS 3070):	
Maximum voltage:	230 V~/=
Maximum current on contact:	6 A
Contact:	change-over switch
Electrical connections:	AMP 6.3 DIN 46248 for bushings according to DIN 46247
Fitting position:	any fitting positions possible (fitting position has to be defined when ordering indicators with defined switch point)
Type of protection:	IP 00 - without protecting cap IP 54 - with protecting cap
Vacuum switch 42 V (HES 2200 BP)	
Contact:	normally open
Breaking capacity:	42 V/6 W as ohmic resistor
Type of protection:	IP 54 – with protecting cap
Electrical connections:	AMP 6.3 DIN 46248 for receptacle for tabs according to connection method, 2 pole

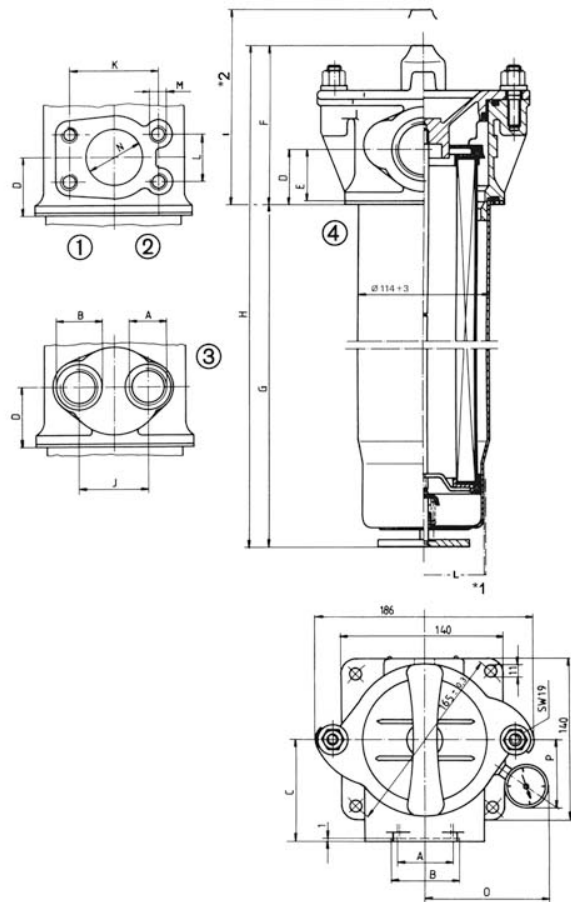

*1 Extension pipe available upon request
*2 Extension height min.

Connecting plan

- 1 supply line
- 2 operating contact
- 3 normally closed contact
- 4 adjusting screw

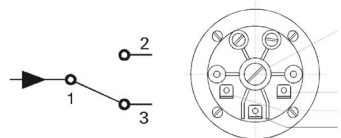

We draw attention to the fact that all values indicated are average values which do not always occur in specific cases of application. Our products are continually being further developed. Values, dimensions and weights can change as a result of this. Our specialized department will be pleased to offer you advice.

We recommend to contact us concerning applications of our filters in areas governed by the EU Directive 94/9 EC (ATEX 95). The standard version can be used for liquids based on mineral oil (corresponding to the fluids in Group 2 of Directive 97/23 EC Article 9). If you consider to use other fluids please contact us for additional support.

Subject to technical alteration without prior notice.

6. Dimensions

Dimension	Pi 1607-...		Pi 1615-...		Pi 1615-...		Pi 1615-...		Pi 1620-...	
O/P	110/64	166	110/64	166	110/64	366	110/64	466	110/64	366
O/P	135/71	165	135/71	165	135/71	365	135/71	465	135/71	365
O/P	130/55	170	130/55	170	130/55	370	130/55	470	130/55	370
Fig.	4		4		2		3		1	
A	G1½		G2		SAE 2"		2 x G1		SAE 3"	
B	56		68				41			
C	87		87		87		87		95	
D	49		49		53		53		73	
E	46		46		50		50		70	
F	144		144		144		144		182	
G	178		471		471		471		433	
H	322		615		615		615		615	
I	375		680		680		680		710	
J							60			
K					77,8				106,4	
L					42,9				61,9	
M					M12				M16	
N					50				76	
Weight [kg]	2.7		3.5		3.5		3.5		5.0	

7. Installation, operating and maintenance instructions

7.1 Filter installation

When installing the filter make sure that sufficient space is available to remove the filter element and the filter housing. Preferably the filter should be installed with the housing pointing downwards.

The maintenance indicator must be visible.

7.2 When should the filter element be replaced or cleaned?

Filters equipped with visual and electrical maintenance indicator: During cold starts, the indicator may give a warning signal. If vacuummeter shows > 0,2 bar or the electrical signal has not switched off after reaching operating temperature, the filter element must be replaced or cleaned after the end of the shift. Please always ensure that you have original MAHLE spare elements in stock: Disposable elements (Mic or Sm-x) cannot be cleaned.

7.3 Element replacement

1. Stop system and relieve filter from pressure.
2. Unscrew nuts, turn cover counter-clockwise and pull. Unscrew element from support.
3. Check O-ring on the filter for damage. Replace, if necessary.
4. Make sure that the order number on the spare element corresponds to the order number of the filter name-plate.
5. Complete installation.

7.4 Cleaning methods for cleanable elements

a) Ultrasonic cleaning

Insert the contaminated suction filter element into an ultrasonic bath for approx. 3 minutes; then rinse in clean liquid. Afterwards, blow air into the filter from the clean side inward.

b) Manual cleaning

1. Remove coarse external contamination in a separate cleaning tank using a brush and cleaning agent.
2. Place filter in unused cleaning liquid (approx. 20 min)
3. Wash filter with cleaning liquid from the outside to the inside.
4. Dry element with pressured-air from the clean side to the dirt side; the cleaning efficiency is about 60–70%

Using either method, be sure that no dirt is entering to the clean side of filter.

8. Spare parts list

Order numbers for spare parts		
Position	Type	Order number
①	Vacuum switch 230 V (PiS 3070/200 mbar)	77669724
②	Vacuum switch 42 V (HES 2200 BP)	78308892
③	Pressure gauge (-1 to 1.5 bar)	76345763
④	Seal kit for filter housing + filter element	
	NBR	77874563
	FPM	77904840
	EPDM	77904857

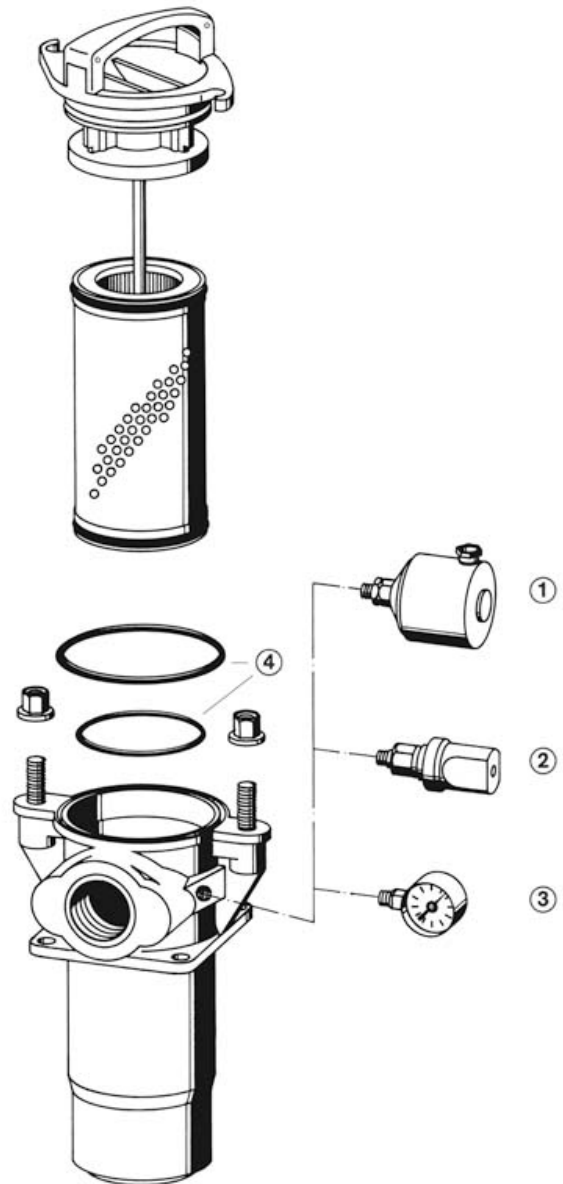

MAHLE Industriefiltration GmbH
 Schleifbachweg 45
 D-74613 Öhringen
 Phone +49 7941 67-0
 Fax +49 7941 67-23429
 industriefiltration@mahle.com
 www.mahle-industriefiltration.com
 78356396.04/2011