

The PFFU-8 is an 8 gpm portable contaminant removal system for use in both above- and below-ground fuel storage tanks. It is designed specifically to remove water and other heavy contaminants common to stored diesel fuel. The standard system operates on 12 VDC power and is lightweight enough for one-person handling and operation. The system is designed for easy storage and does not utilize a filter or moving parts.

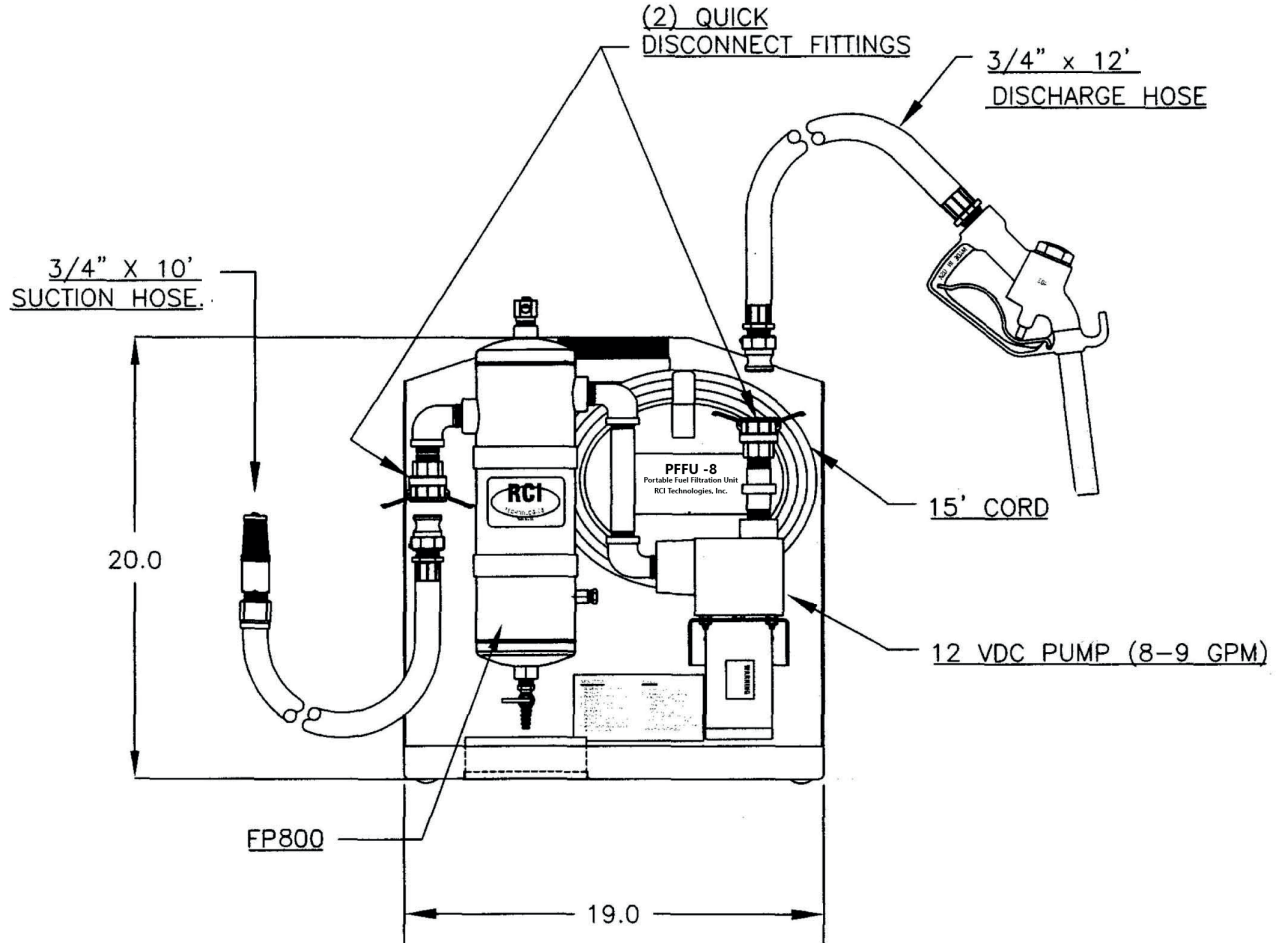

Product Details

| | |
|--------------|-------------------------------|
| Product Line | Portable Fuel Filtration Unit |
| Model | PFFU-8 |
| Dimensions | 20" H x 19" W x 15" D |
| Weight | 45 lbs. |

Pump and Motor

| | |
|-------------------------|--------------|
| Standard Power | 12 VDC |
| Motor Horse Power | 1/5 |
| Motor Operation | Self-Priming |
| Max. Operating Pressure | 78 psi |
| Pump Horse Power | 1/5 hp |
| Pump Operation | Portable |
| Nominal Flow | 8 gpm |

Fuel Purifier

| | |
|---------------------|-------------|
| Model Number | FP 800 |
| Nominal Flow | 8 gpm |
| Water Drain Port | 1/2" |
| Free Water Removal | up to 99.8% |
| Contaminant Removal | up to 95% |

Hoses

| | |
|--|------------|
| Detachable Foot Suction Hose | 10' x 3/4" |
| Detachable Foot Pressure Hose | 12' x 3/4" |
| Manual Shut-Off Nozzle | 3/4" |
| Quick-Release Aluminum Cam Lock Coupling | 1" (2) |

Additional Features

- 90-Degree Swivel Couplings
- 15' Power Cord
- One Year Manufacturer's Warranty on pump

