

The PFFU-50 is a 50 gpm high-volume portable contaminant removal system for use in both above- and below-ground fuel storage tanks. It is designed specifically to remove water and other heavy contaminants common to stored diesel fuel. Options include: bag filter for sludge removal, high-efficiency fuel filter, three-phase fuel coalescer with a 95% single-pass water removal efficiency, and power upgrades.

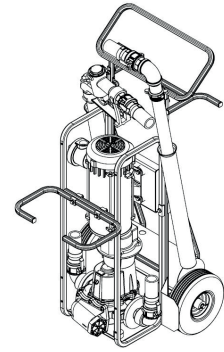

NOTE: Fuel purifier and hoses not shown on drawing. See photograph below.

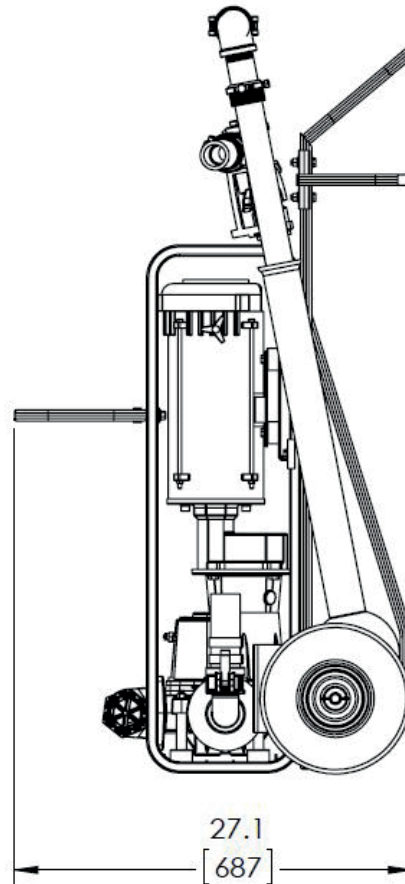
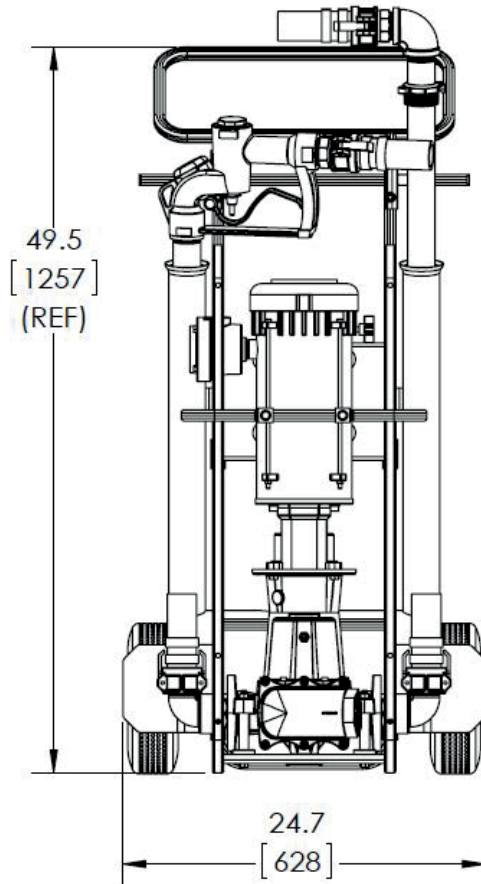

Product Details

Product Line	Portable Fuel Polishing Unit
Model	PFFU-50
Dimensions	50" H x 25" W x 31" D
Weight	305 lbs.

Pump and Motor

Standard Power	115/230VAC, 60 Hz, Single Phase 14.4 FLA @ 120VAC
Motor Horse Power	1.5 hp
Motor Operation	Self-Priming, Explosion-Proof Motor
Max. Operating Pressure	78 psi
Pump Operation	Positive-Displacement Transfer Pump
Pump Head	1.5" Blade Master

Fuel Purifier

Model Number	FP 1500
Nominal Flow	50 gpm
Water Drain Port	1"
Free Water Removal	up to 99.8%
Contaminant Removal	up to 95%

Hoses

Suction Hose	1-1/2" x 10' - Explosion-Proof
Pressure Hose	1-1/2" x 10' - Explosion-Proof
Manual Shut-Off Nozzle	1-1/2"

Optional Filtration

Three-Phase Coalescer	5 micron
Emulsified Water Removal	95% Single-Pass Water Removal
High-Efficiency Fuel Filter	3 micron

Additional Features

- 1.5" Manual Shut-Off Nozzle
- 90-Degree Swivel Couplings
- 50' Power Cord
- 4' Aluminum Suction Tube
- Quick-Release Aluminum Camlock Couplings
- One Year Manufacturer's Warranty on Pump
- Optional: Bag Filter, High-Efficiency Fuel Filter, Three-Phase Fuel Coalescer

