

Specifications

Specification	AH55546 • AH55562
Length, Overall	25.0" (634.9 mm)
Width, Overall	18.5" (468.8 mm)
Height, Overall	14.6" (369.6 mm)
Flow, Min. at 2" H ₂ O (0.5 kPa) Restriction	270 CFM (7.7 m ³ /min)
Flow, Max. at 12" H ₂ O (3.0 kPa) Restriction	771 CFM (21.8 m ³ /min)
Secondary Element	Yes
Housing Material	Glass-Filled Polyamide and Metal
Pre-Cleaner	No
Inlet	90° to Outlet, 5.0" (127 mm)
Outlet	Straight, 6.0" (152 mm)
Filter Efficiency	≥ 99.90% per ISO 5011

Specifications subject to change without notice.

Dust Holding Capacity per Flow Rate

Specification	Non Aspirated	
	CFM	m ³ /min
Maximum Flow for 10 g/CFM (3500 g/m ³ /min)	380	10.8
Maximum Flow for 25 g/CFM (8750 g/m ³ /min)	N/A*	N/A*

*Requires precleaner (optional)

Dimensions

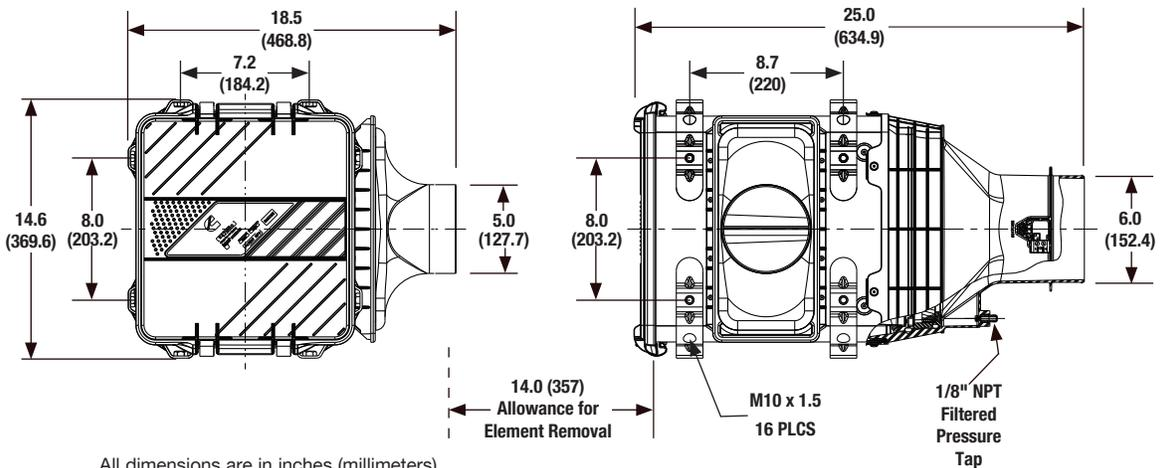

All dimensions are in inches (millimeters)

Ordering Information

Air Cleaners	
Part Number	Description
AH55546	Direct Flow - Side Inlet - With TBAP Sensor
AH55562	Direct Flow - Side Inlet - Without TBAP Sensor

TBAP -Temperature and Barometric Air Pressure

Service Parts	
Part Number	Description
AF55015	Primary Element
AF55309	Secondary Element
SP1003	Front Service Cover
SP1187	Service Cover Latches

Optional Accessories	
Part Number	Description
3316658S	4" Band Clamp
3316660S	5" Band Clamp
3316662S	6" Band Clamp
3316608S	4" Hump Hose
3316610S	5" Hump Hose
3316612S	6" Hump Hose
3316568S	4" 90° Elbow
3316570S	5" 90° Elbow
3316573S	6" 90° Elbow
3316589S	6" to 5" Reducing Elbow
3316618S	5" to 4" Hump Hose Reducer
3316621S	6" to 5" Hump Hose Reducer
3946466S	Weather Hood
3905161S	Restriction Indicator

Additional sizes/shapes may be available.
Refer to the Cummins Filtration catalog or website.

Performance

System Restriction vs Flow Rate

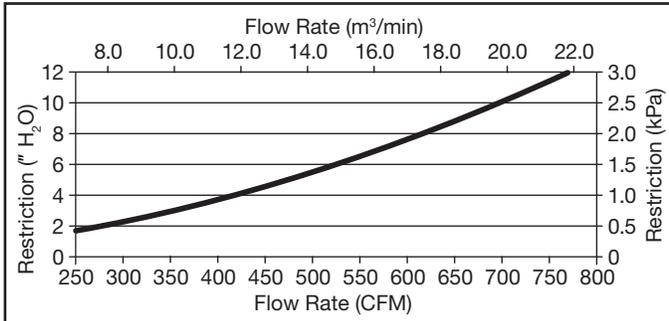

System Capacity vs Flow Rate

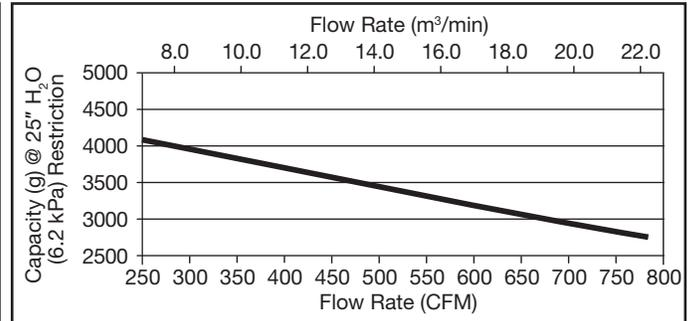

Restriction		Flow Rate		Typical Capacity at 25" H ₂ O (6.2 kPa) of Terminal Restriction
in H ₂ O	kPa	CFM	m³/min	Non Aspirated (g)
4	1.0	418	11.8	3645
6	1.5	526	14.9	3373
8	2.0	617	17.5	3146
10	2.5	698	19.8	2949
12	3.0	771	21.8	2772

ISO Fine Dust
1.0 g/m³ Feed Rate
25" H₂O (6.2 kPa)
Terminal Restriction
per ISO 5011

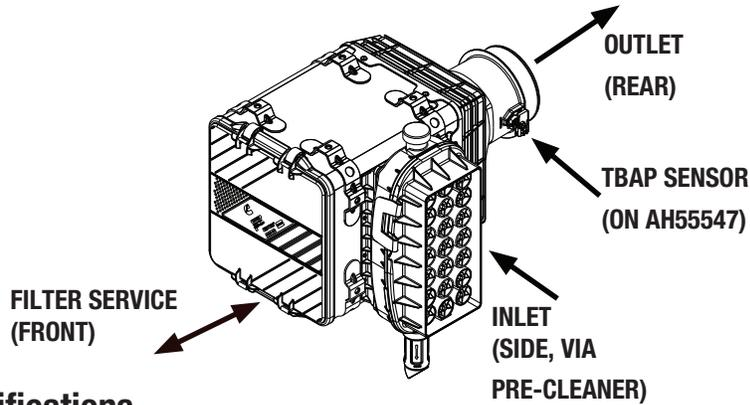

Specifications

Specification	AH55547 • AH55563
Length, Overall	25.0" (634.9 mm)
Width, Overall	18.7" (474.6 mm)
Height, Overall	21.6" (548.5 mm)
Flow, Min. at 2" H ₂ O (0.5 kPa) Restriction	260 CFM (7.4 m ³ /min)
Flow, Max. at 12" H ₂ O (3.0 kPa) Restriction	690 CFM (19.5 m ³ /min)
Secondary Element	Yes
Housing Material	Glass-Filled Polyamide and Metal
Pre-Cleaner	Integral, Spinner-tube Type
Inlet	Via Pre-Cleaner, 90° to outlet
Outlet	Straight, 6.0" (152 mm)
Filter Efficiency	≥ 99.90% per ISO 5011

Specifications subject to change without notice.

Dust Holding Capacity per Flow Rate

Specification	Aspirated		Non Aspirated	
	CFM	m ³ /min	CFM	m ³ /min
Maximum Flow for 10 g/CFM (3500 g/m ³ /min)	690*	19.5*	690*	19.5*
Maximum Flow for 25 g/CFM (8750 g/m ³ /min)	690*	19.5*	600	17.0

*Indicates maximum recommended flow rate

Dimensions

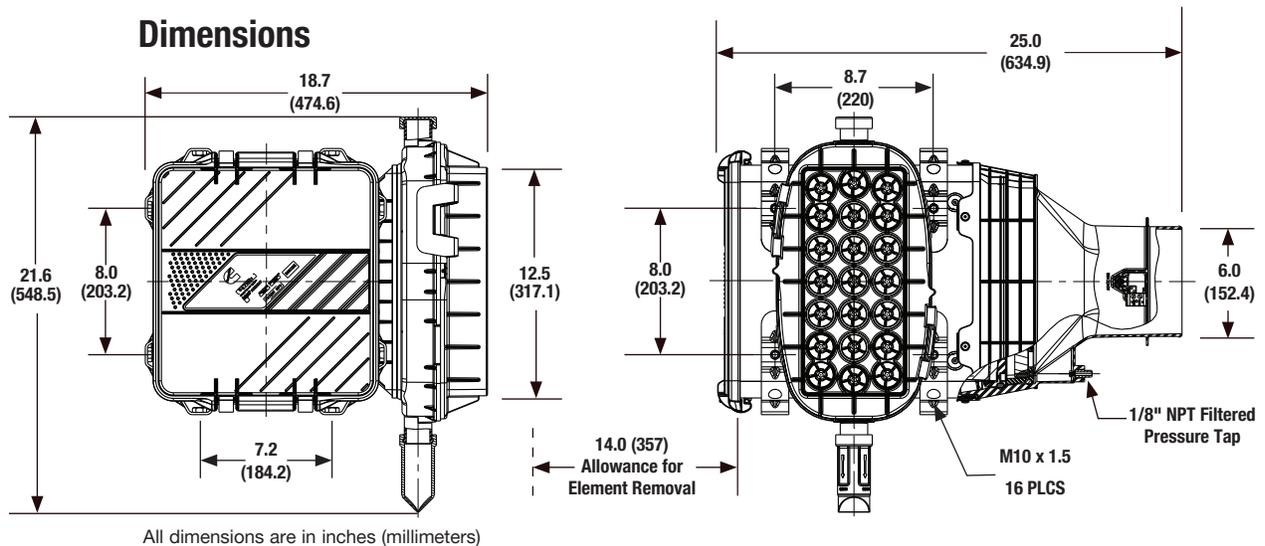

All dimensions are in inches (millimeters)

Ordering Information

Air Cleaners	
Part Number	Description
AH55547	Direct Flow - Side Inlet - Integrated Pre-Cleaner - With TBAP Sensor
AH55563	Direct Flow - Side Inlet - Integrated Pre-Cleaner - Without TBAP Sensor

TBAP -Temperature and Barometric Air Pressure

Service Parts	
Part Number	Description
AF55015	Primary Element
AF55309	Secondary Element
SP1003	Front Service Cover
SP1048	Angled Dust Ejection Valve (DEV)
SP1004	Service Kit: Straight DEV Tube, DEV Cap, J-Clips (4)
SP1187	Service Cover Latches

Optional Accessories	
Part Number	Description
3316658S	4" Band Clamp
3316660S	5" Band Clamp
3316662S	6" Band Clamp
3316608S	4" Hump Hose
3316610S	5" Hump Hose
3316612S	6" Hump Hose
3316568S	4" 90° Elbow
3316570S	5" 90° Elbow
3316573S	6" 90° Elbow
3316589S	6" to 5" Reducing Elbow
3316618S	5" to 4" Hump Hose Reducer
3316621S	6" to 5" Hump Hose Reducer
3946466S	Weather Hood
3905161S	Restriction Indicator

Additional sizes/shapes may be available. Refer to the Cummins Filtration catalog or website.

Performance

System Restriction vs Flow Rate

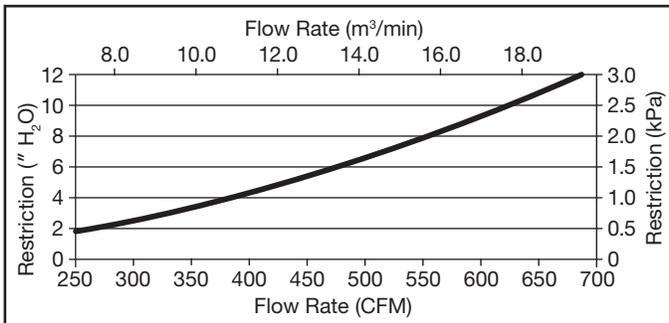

System Capacity vs Flow Rate

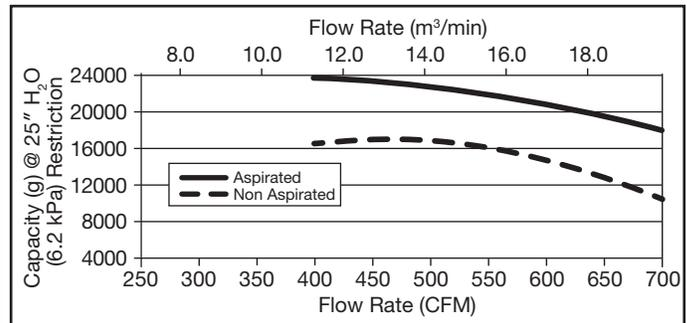

Restriction		Flow Rate		Typical Capacity at 25" H ₂ O (6.2 kPa) of Terminal Restriction	
in H ₂ O	kPa	CFM	m³/min	Aspirated (g)	Non Aspirated (g)
4	1.0	384	10.9	23206	16274
6	1.5	478	13.5	22996	16922
8	2.0	557	15.8	21723	15901
10	2.5	627	17.8	19767	13816
12	3.0	690	19.5	17324	10969

ISO Coarse Dust
2.0 g/m³ Feed Rate
25" H₂O (6.2 kPa)
Terminal Restriction
per ISO 5011

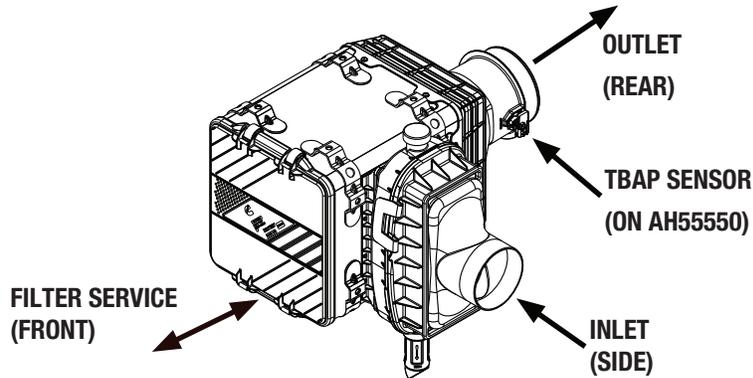

Specifications

Specification	AH55550 • AH55564
Length, Overall	25.0" (634.9 mm)
Width, Overall	23.4" (595.3 mm)
Height, Overall	21.6" (548.5 mm)
Flow, Min. at 2" H ₂ O (0.5 kPa) Restriction	240 CFM (6.80 m ³ /min)
Flow, Max. at 12" H ₂ O (3.0 kPa) Restriction	650 CFM (18.4 m ³ /min)
Secondary Element	Yes
Housing Material	Glass-Filled Polyamide and Metal
Pre-Cleaner	Integral, Vortex Tube Type
Inlet	90° to Outlet, 5.0" (127 mm)
Outlet	Straight, 6.0" (152.4 mm)
Filter Efficiency	≥ 99.90% per ISO 5011

Specifications subject to change without notice.

Dust Holding Capacity per Flow Rate

Specification	Aspirated		Non Aspirated	
	CFM	m ³ /min	CFM	m ³ /min
Maximum Flow for 10 g/CFM (3500 g/m ³ /min)	650*	18.4*	650*	18.4*
Maximum Flow for 25 g/CFM (8750 g/m ³ /min)	650*	18.4*	400	11.3

*Indicates maximum recommended flow rate

Dimensions

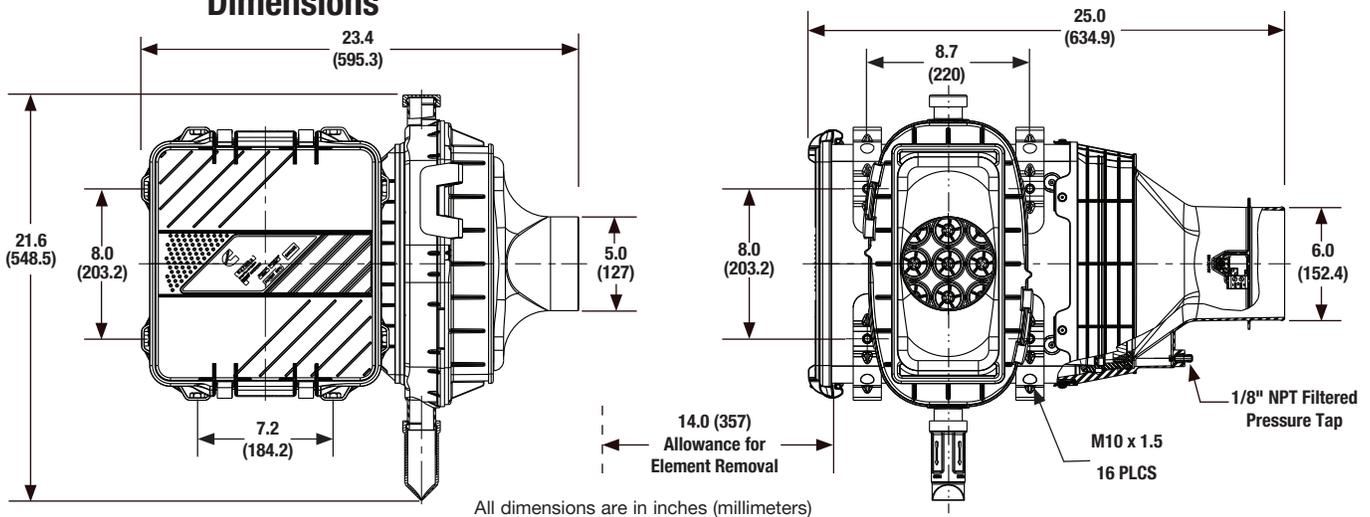

All dimensions are in inches (millimeters)

Ordering Information

Air Cleaners	
Part Number	Description
AH55550	Direct Flow - Integrated Pre-Cleaner - Side Inlet - With TBAP Sensor
AH55564	Direct Flow - Integrated Pre-Cleaner - Side Inlet - Without TBAP Sensor

TBAP -Temperature and Barometric Air Pressure

Service Parts	
Part Number	Description
AF55015	Primary Element
AF55309	Secondary Element
SP1003	Front Service Cover
SP1048	Angled Dust Ejection Valve (DEV)
SP1004	Service Kit: Straight DEV Tube, DEV Cap, J-Clips (4)
SP1187	Service Cover Latches

Optional Accessories	
Part Number	Description
3316658S	4" Band Clamp
3316660S	5" Band Clamp
3316662S	6" Band Clamp
3316608S	4" Hump Hose
3316610S	5" Hump Hose
3316612S	6" Hump Hose
3316568S	4" 90° Elbow
3316570S	5" 90° Elbow
3316573S	6" 90° Elbow
3316589S	6" to 5" Reducing Elbow
3316618S	5" to 4" Hump Hose Reducer
3316621S	6" to 5" Hump Hose Reducer
3946466S	Weather Hood
3905161S	Restriction Indicator

Additional sizes/shapes may be available. Refer to the Cummins Filtration catalog or website.

Performance

System Restriction vs Flow Rate

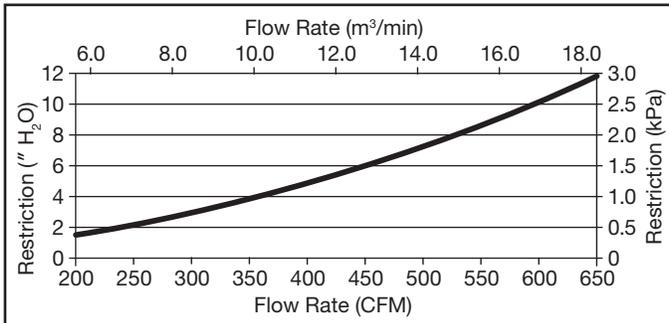

System Capacity vs Flow Rate

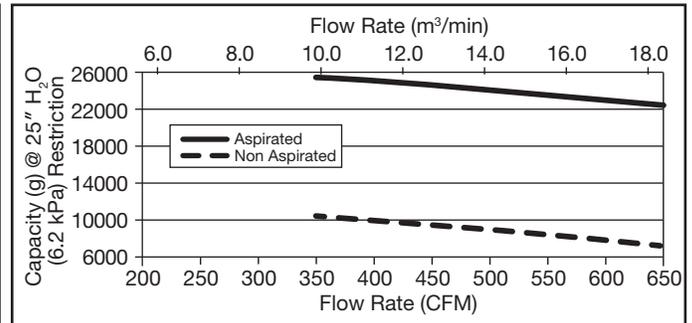

Restriction		Flow Rate		Typical Capacity at 25" H ₂ O (6.2 kPa) of Terminal Restriction	
" H ₂ O	kPa	CFM	m³/min	Aspirated (g)	Non Aspirated (g)
4	1.0	357	10.1	25446	10351
6	1.5	445	12.6	24668	9530
8	2.0	520	14.7	23906	8751
10	2.5	586	16.6	23153	8000
12	3.0	650	18.4	22407	7214

ISO Coarse Dust
2.0 g/m³ Feed Rate
25" H₂O (6.2 kPa)
Terminal Restriction
per ISO 5011

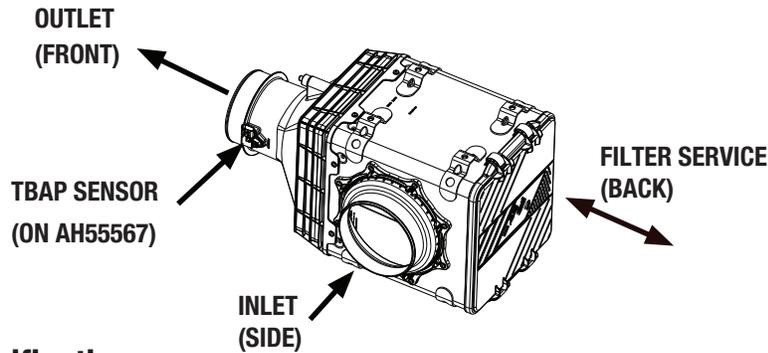

Specifications

Specification	AH55676 • AH55677
Length, Overall	25.4" (644.2 mm)
Width, Overall	15.2" (386.9 mm)
Height, Overall	14.6" (369.6 mm)
Flow, Min. at 2" H ₂ O (0.5 kPa) Restriction	340 CFM (9.6 m ³ /min)
Flow, Max. at 12" H ₂ O (3.0 kPa) Restriction	1000 CFM (28.3 m ³ /min)
Secondary Element	Yes
Housing Material	Glass-Filled Polyamide and Metal
Pre-Cleaner	No
Inlet	90° to Outlet, 7.0" (178 mm)
Outlet	Straight, 6.0" (152 mm)
Filter Efficiency	≥ 99.90% per ISO 5011

Specifications subject to change without notice.

Dust Holding Capacity per Flow Rate

Specification	Non Aspirated	
	CFM	m ³ /min
Maximum Flow for 10 g/CFM (3500 g/m ³ /min)	270	7.6
Maximum Flow for 25 g/CFM (8750 g/m ³ /min)	N/A*	N/A*

*Requires precleaner (optional)

Dimensions

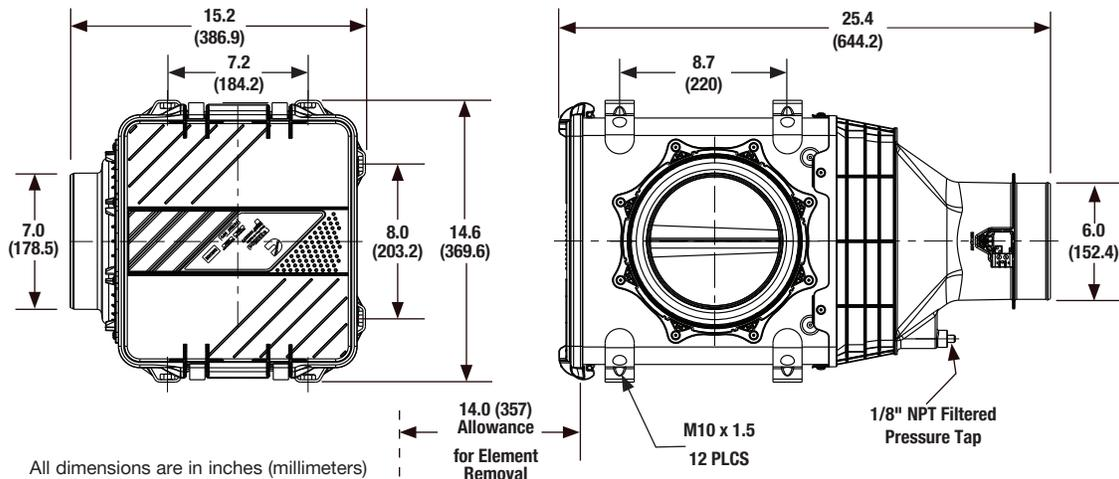

All dimensions are in inches (millimeters)

Ordering Information

Air Cleaners	
Part Number	Description
AH55676	Direct Flow - Side Inlet - Without TBAP Sensor
AH55677	Direct Flow - Side Inlet - With TBAP Sensor

TBAP -Temperature and Barometric Air Pressure

Service Parts	
Part Number	Description
AF55015	Primary Element
AF55309	Secondary Element
SP1003	Front Service Cover
SP1187	Service Cover Latches

Optional Accessories	
Part Number	Description
3316658S	4" Band Clamp
3316660S	5" Band Clamp
3316662S	6" Band Clamp
3316608S	4" Hump Hose
3316610S	5" Hump Hose
3316612S	6" Hump Hose
3316568S	4" 90° Elbow
3316570S	5" 90° Elbow
3316573S	6" 90° Elbow
3316589S	6" to 5" Reducing Elbow
3316618S	5" to 4" Hump Hose Reducer
3316621S	6" to 5" Hump Hose Reducer

Additional sizes/shapes may be available.
Refer to the Cummins Filtration catalog or website.

Performance

System Restriction vs Flow Rate

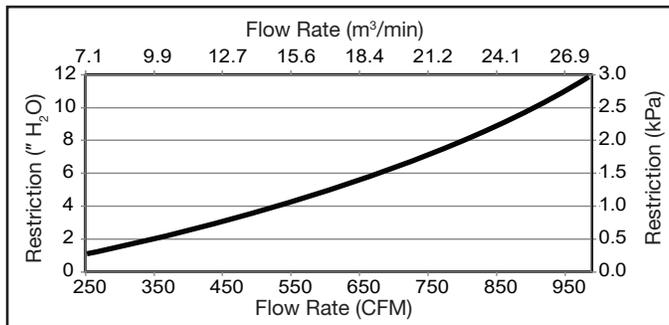

System Capacity vs Flow Rate

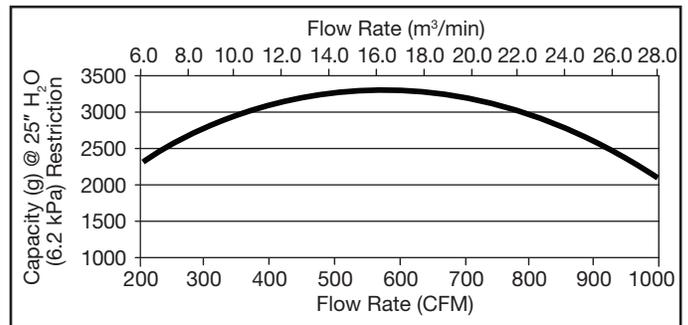

Restriction		Flow Rate		Typical Capacity at 25" H ₂ O (6.2 kPa) of Terminal Restriction
in H ₂ O	kPa	CFM	m³/min	Non-Aspirated (g)
4	1.0	540	15.3	3300
6	1.5	680	19.3	3200
8	2.0	800	22.7	3050
10	2.5	900	25.5	2550
12	3.0	1000	28.3	1900

ISO Fine Dust
1.0 g/m³ Feed Rate
25" H₂O (6.2 kPa)
Terminal Restriction
per ISO 5011

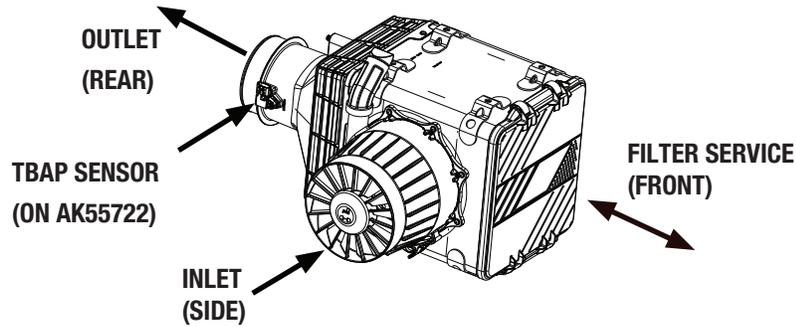

Specifications

Specification	AK55722 • AK55723
Length, Overall	25.4" (644.2 mm)
Width, Overall	14.6" (369.6 mm)
Height, Overall	21.1" (534.9 mm)
Flow, Min. at 2" H ₂ O (0.5 kPa) Restriction	300 CFM (8.5 m ³ /min)
Flow, Max. at 12" H ₂ O (3.0 kPa) Restriction	825 CFM (23.4 m ³ /min)
Secondary Element	Yes
Housing Material	Glass-Filled Polyamide and Metal
Pre-Cleaner	No
Inlet	90° to Outlet, 8.0" (203 mm)
Outlet	Straight, 6.0" (152 mm)
Filter Efficiency	≥ 99.90% per ISO 5011

Specifications subject to change without notice.

Dust Holding Capacity per Flow Rate

Specification	CFM	m ³ /min
Maximum Flow for 10 g/CFM (3500 g/m ³ /min)	825*	23.4*
Maximum Flow for 25 g/CFM (8750 g/m ³ /min)	380	10.8

*Indicates maximum recommended flow rate

Dimensions

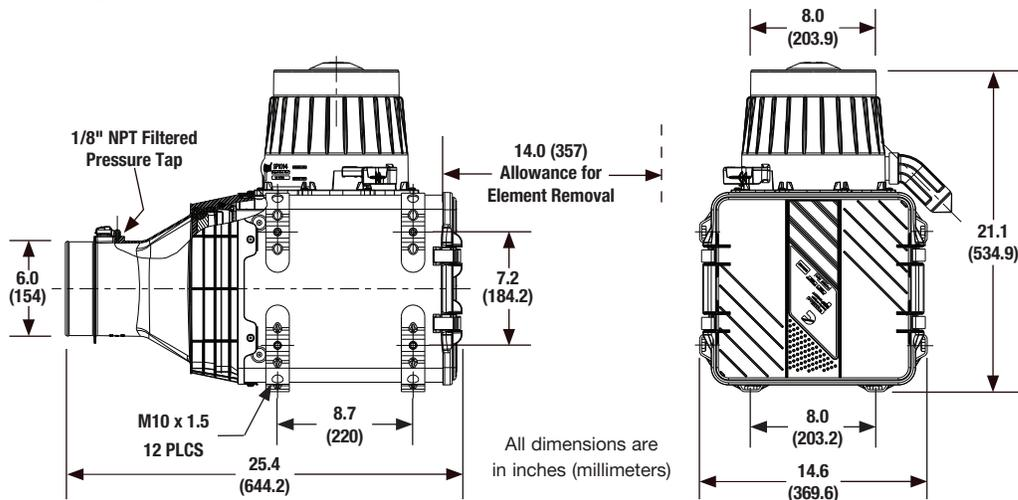

Ordering Information

Air Cleaners		Service Parts		Optional Accessories	
Part Number	Description	Part Number	Description	Part Number	Description
AK55722	Direct Flow - Side Inlet - Integrated Pre-Cleaner - With TBAP Sensor	AF55015	Primary Element	3316658S	4" Band Clamp
	AK55723	Direct Flow - Side Inlet - Integrated Pre-Cleaner - Without TBAP Sensor	AF55309	Secondary Element	3316660S
			SP1003	Front Service Cover	3316662S
		SP1048	Angled Dust Ejection Valve (DEV)	3316608S	4" Hump Hose
		SP1014	Pre-Cleaner Assembly	3316610S	5" Hump Hose
		SP1187	Service Cover Latches	3316612S	6" Hump Hose
				3316568S	4" 90° Elbow
				3316570S	5" 90° Elbow
				3316573S	6" 90° Elbow
				3316589S	6" to 5" Reducing Elbow
				3316618S	5" to 4" Hump Hose Reducer
				3316621S	6" to 5" Hump Hose Reducer
				3946466S	Weather Hood
				3905161S	Restriction Indicator

TBAP -Temperature and Barometric Air Pressure

Additional sizes/shapes may be available.
Refer to the Cummins Filtration catalog or website.

Performance

System Restriction vs Flow Rate

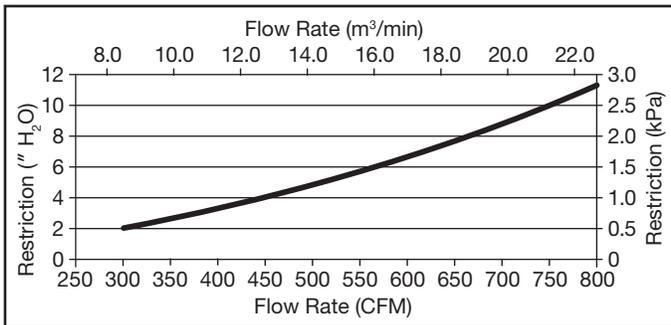

System Capacity vs Flow Rate

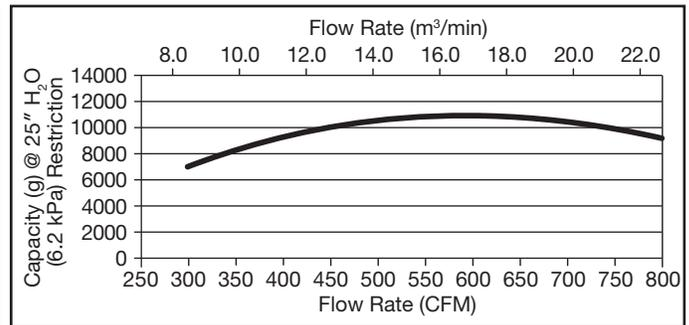

Restriction		Flow Rate		Typical Capacity at 25" H ₂ O (6.2 kPa) of Terminal Restriction
in H ₂ O	kPa	CFM	m³/min	Non-Aspirated (g)
4	1.0	450	12.7	10000
6	1.5	560	15.9	10500
8	2.0	670	19.0	10800
10	2.5	750	21.2	10000
12	3.0	825	23.4	8800

ISO Coarse Dust
2.0 g/m³ Feed Rate
25" H₂O (6.2 kPa)
Terminal Restriction
per ISO 5011