

## Specifications

Specification	AH55579
Length, Overall	18.5" (469.2 mm)
Width, Overall	9.5" (241.3 mm)
Height, Overall	12.7" (322.8 mm)
Flow, Min. at 2" H <sub>2</sub> O (0.5 kPa) Restriction	133 CFM (3.8 m <sup>3</sup> /min)
Flow, Max. at 12" H <sub>2</sub> O (3.0 kPa) Restriction	341 CFM (9.6 m <sup>3</sup> /min)
Secondary Element	Yes
Housing Material	Glass-filled Polyamide
Pre-Cleaner	No
Inlet	90° to Outlet, 5.0" (Ø127.0 mm)
Outlet	Straight, 4.0" (Ø101.6 mm)
Filter Efficiency	≥ 99.90% per ISO 5011

Specifications Subject to change without notice.

## Dust Holding Capacity per Flow Rate

Specification	Non Aspirated	
	CFM	m <sup>3</sup> /min
Maximum Flow for 10 g/CFM (357.1 g/m <sup>3</sup> /min)	137*	3.9*
Minimum Flow for 25 g/CFM (892.9 g/m <sup>3</sup> /min)	N/A	N/A

\*Indicates maximum recommended flow rate.

## Dimensions

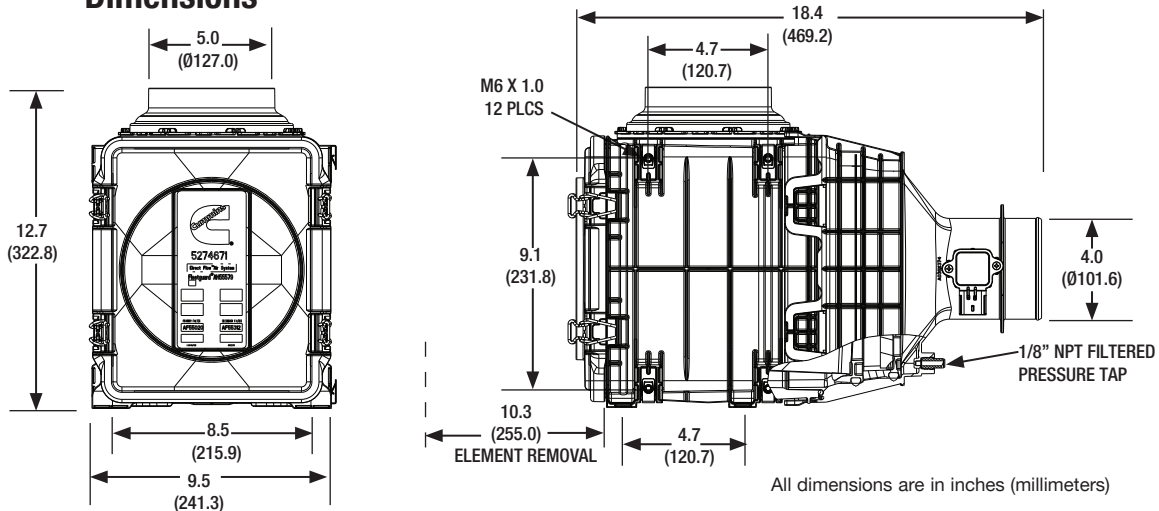

All dimensions are in inches (millimeters)

## Ordering Information

Air Cleaners	
Part Number	Description
AH55579	Direct Flow -Front Inlet -With MAF Sensor

Service Parts	
Part Number	Description
AF55020	Primary Element
AF55312	Secondary Element
SP1048	Dust Ejection Valve (DEV)
SP1060	M6 Mounting Clips
SP1041	Front Service Cover

Optional Accessories	
Part Number	Description
3316658S	4" Band Clamp
3316660S	5" Band Clamp
3316608S	4" Hump Hose
3316610S	5" Hump Hose
3316568S	4" 90° Elbow
3316570S	5" 90° Elbow
3316618S	5" to 4" Hump Hose Reducer
3946329S	Restriction Indicator

Additional sizes/shapes may be available. Refer to the Cummins Filtration catalog or website.

## Performance

### System Restriction vs Flow Rate

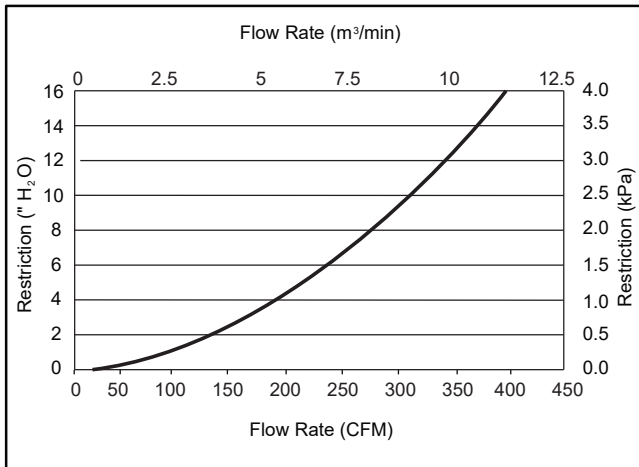

### System Capacity vs Flow Rate

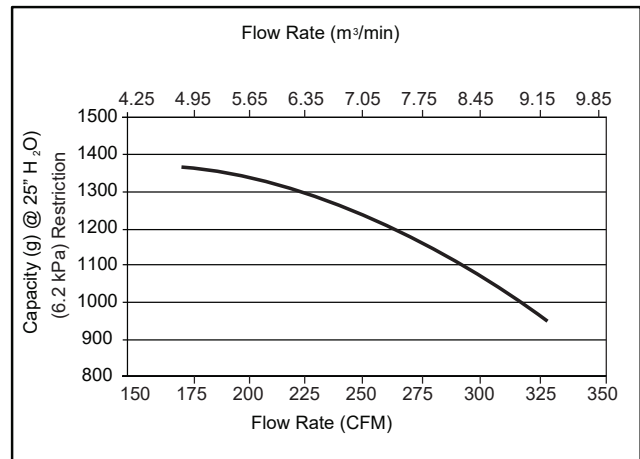

Restriction		Flow Rate		Typical Capacity at 25" H <sub>2</sub> O (6.2 kPa) of Terminal Restriction
in H <sub>2</sub> O	kPa	CFM	m³/min	Non Aspirated (g)
4	1.0	185	5.2	1352.6
6	1.5	231	6.5	1274.2
8	2.0	272	7.7	1153.6
10	2.5	309	8.7	1006.9
12	3.0	341	9.6	848.4

ISO Fine Dust  
1.0 g/m<sup>3</sup> Feed Rate  
25" H<sub>2</sub>O (6.2 kPa)  
Terminal Restriction  
per ISO 5011

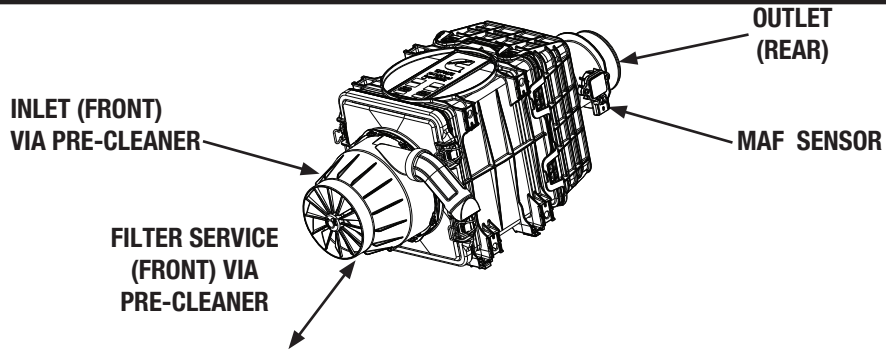

## Specifications

Specification	AH55582
Length, Overall	24.4" (620.7 mm)
Width, Overall	9.5" (241.3 mm)
Height, Overall	10.9" (277.4 mm)
Flow, Min. at 2" H <sub>2</sub> O (0.5 kPa) Restriction	120 CFM (3.4 m <sup>3</sup> /min)
Flow, Max. at 12" H <sub>2</sub> O (3.0 kPa) Restriction	308 CFM (8.7 m <sup>3</sup> /min)
Secondary Element	Yes
Housing Material	Glass-filled Polyamide
Pre-Cleaner	Integrated
Inlet	Straight - via Pre-Cleaner, 5.0" (Ø127.0 mm)
Outlet	Straight, 4.0" (Ø101.6 mm)
Filter Efficiency	≥ 99.90% per ISO 5011

Specifications Subject to change without notice.

## Dust Holding Capacity per Flow Rate

Specification	Non Aspirated	
	CFM	m <sup>3</sup> /min
Maximum Flow for 10 g/CFM (357.1 g/m <sup>3</sup> /min)	298*	8.4*
Minimum Flow for 25 g/CFM (892.9 g/m <sup>3</sup> /min)	152	4.3

\*Indicates maximum recommended flow rate.

## Dimensions

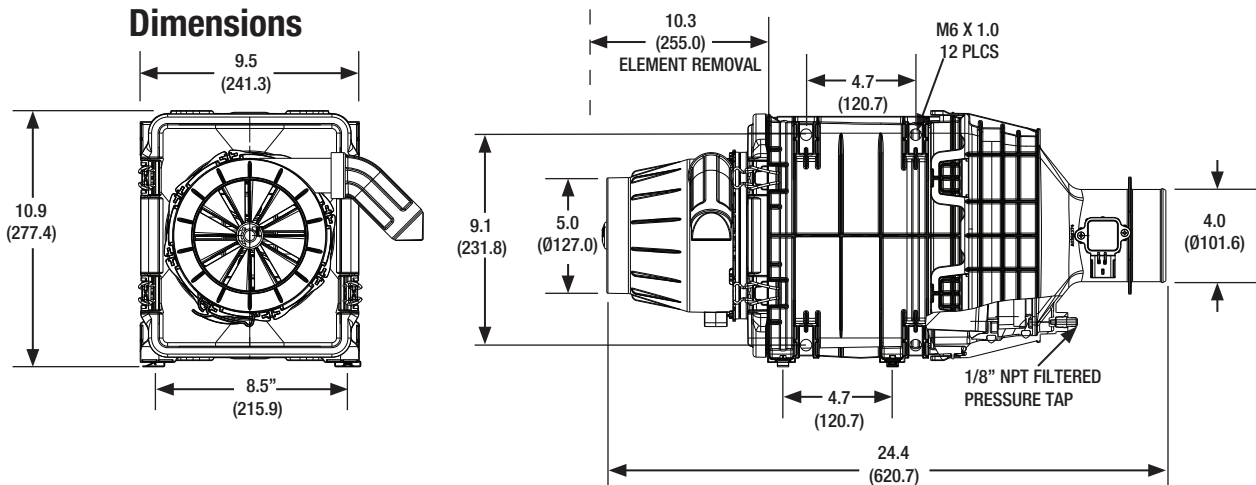

All dimensions are in inches (millimeters)

## Ordering Information

Air Cleaners	
Part Number	Description
AH55582	Direct Flow -Integrated Pre-Cleaner -Front Inlet -With MAF Sensor

Service Parts	
Part Number	Description
AF55020	Primary Element
AF55312	Secondary Element
AP15909	Pre-Cleaner
SP1054	Mass Airflow Sensor
SP1048	Dust Ejection Valve (DEV)
SP1060	M6 Mounting Clips
SP1042	Front Service Cover

Optional Accessories	
Part Number	Description
3316658S	4" Band Clamp
3316660S	5" Band Clamp
3316608S	4" Hump Hose
3316610S	5" Hump Hose
3316568S	4" 90° Elbow
3316570S	5" 90° Elbow
3316618S	5" to 4" Hump Hose Reducer
3946329S	Restriction Indicator

Additional sizes/shapes may be available. Refer to the Cummins Filtration catalog or website.

## Performance

### System Restriction vs Flow Rate

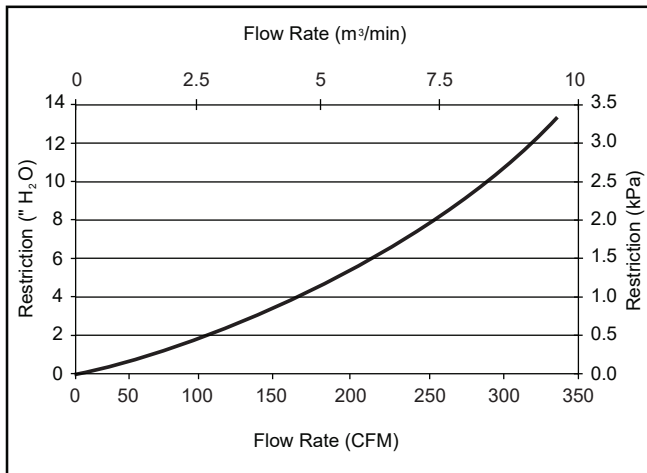

### System Capacity vs Flow Rate

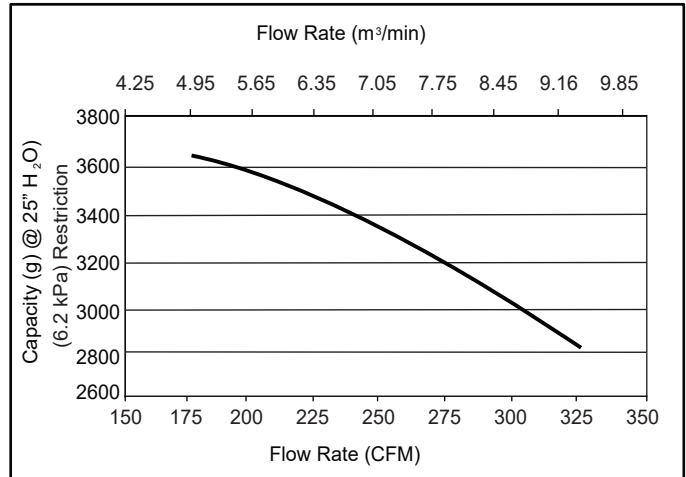

Restriction		Flow Rate		Typical Capacity at 25" H <sub>2</sub> O (6.2 kPa) of Terminal Restriction	Typical Capacity at 30" H <sub>2</sub> O (6.2 kPa) of Terminal Restriction
in H <sub>2</sub> O	kPa	CFM	m³/min	Non Aspirated (g)	Non Aspirated (g)
4	1.0	170	4.8	3650	3730
6	1.5	213	6.0	3480	3590
8	2.0	248	7.0	3310	3500
10	2.5	280	7.9	3120	3440
12	3.0	308	8.7	2920	3390

ISO Coarse Dust  
2.0 g/m<sup>3</sup> Feed Rate  
25" H<sub>2</sub>O (6.2 kPa)  
Terminal Restriction  
per ISO 5011

# DF390 MAF Series

# Direct Flow Air Cleaners

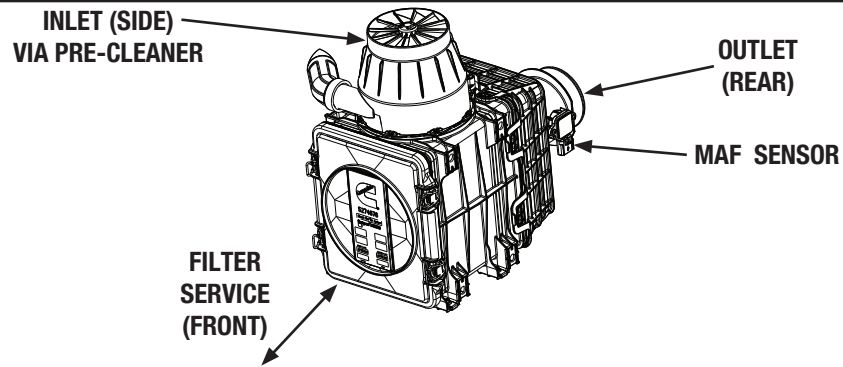

## Specifications

Specification	AH55583
Length, Overall	18.4" (469.2 mm)
Width, Overall	9.5" (241.3 mm)
Height, Overall	16.6" (423.4 mm)
Flow, Min. at 2" H <sub>2</sub> O (0.5 kPa) Restriction	115 CFM (3.3 m <sup>3</sup> /min)
Flow, Max. at 12" H <sub>2</sub> O (3.0 kPa) Restriction	308 CFM (8.7 m <sup>3</sup> /min)
Secondary Element	Yes
Housing Material	Glass-filled Polyamide
Pre-Cleaner	Integrated
Inlet	90° to Outlet - via Pre-Cleaner, 5.0" (Ø127.00.0 mm)
Outlet	Straight, 4.0" (Ø101.6 mm)
Filter Efficiency	≥ 99.90% per ISO 5011

Specifications Subject to change without notice.

## Dust Holding Capacity per Flow Rate

Specification	Non Aspirated	
	CFM	m <sup>3</sup> /min
Maximum Flow for 10 g/CFM (357.1 g/m <sup>3</sup> /min)	296*	8.4*
Maximum Flow for 25 g/CFM (892.9 g/m <sup>3</sup> /min)	152	4.3

\*Indicates maximum recommended flow rate.

## Dimensions

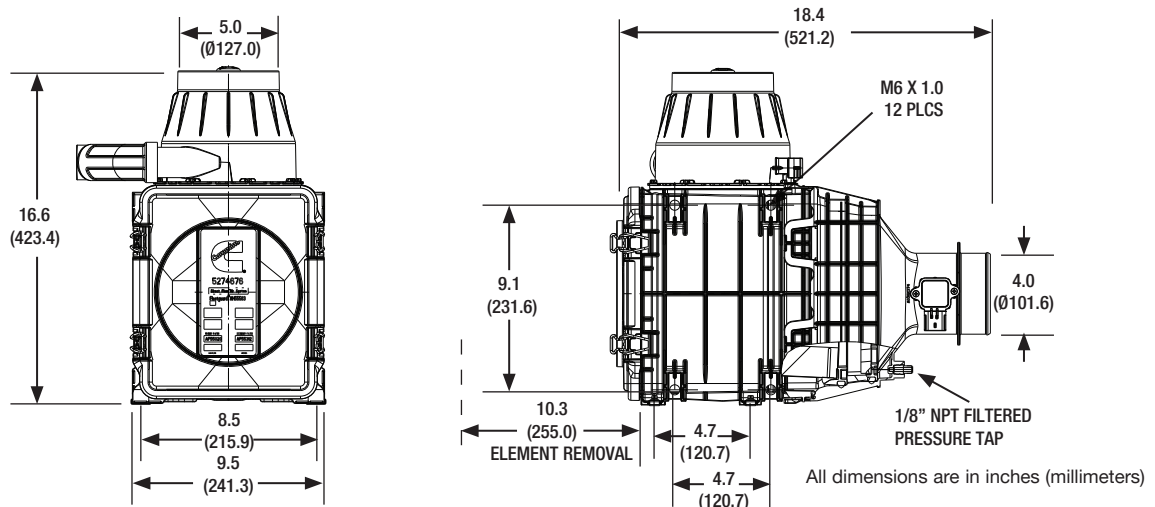

## Ordering Information

Air Cleaners	
Part Number	Description
AH55583	Direct Flow -Integrated Pre-Cleaner -Side Inlet -With MAF Sensor

Service Parts	
Part Number	Description
AF55020	Primary Element
AF55312	Secondary Element
SP1054	Mass Airflow Sensor
SP1041	Front Service Cover
SP1048	Dust Ejection Valve (DEV)
SP1060	M6 Mounting Clips
AP15909	Pre-Cleaner

Optional Accessories	
Part Number	Description
3316658S	4" Band Clamp
3316660S	5" Band Clamp
3316608S	4" Hump Hose
3316610S	5" Hump Hose
3316568S	4" 90° Elbow
3316570S	5" 90° Elbow
3316618S	5" to 4" Hump Hose Reducer
3946329S	Restriction Indicator

Additional sizes/shapes may be available.  
Refer to the Cummins Filtration catalog or website.

## Performance

### System Restriction vs Flow Rate

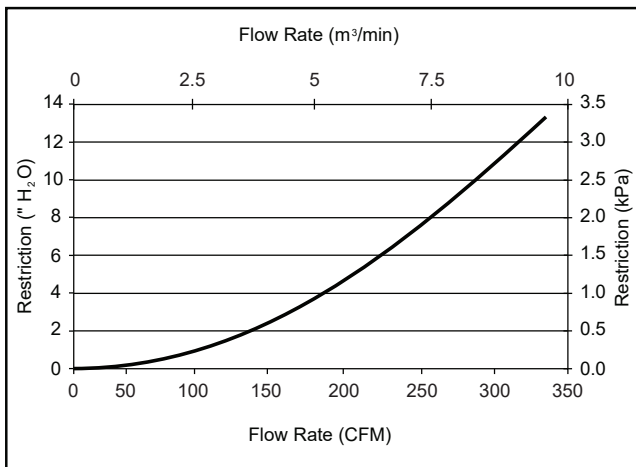

### System Capacity vs Flow Rate

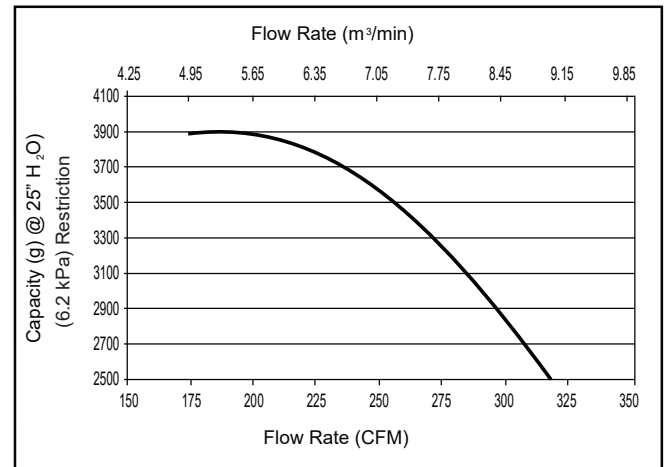

Restriction		Flow Rate		Typical Capacity at 25" H <sub>2</sub> O (6.2 kPa) of Terminal Restriction	Typical Capacity at 30" H <sub>2</sub> O (6.2 kPa) of Terminal Restriction
in H <sub>2</sub> O	kPa	CFM	m <sup>3</sup> /min	Non Aspirated (g)	Non Aspirated (g)
4	1.0	165	4.6	3850	3970
6	1.5	210	6.0	3840	3960
8	2.0	248	7.0	3580	3790
10	2.5	280	7.9	3200	3520
12	3.0	308	8.7	2730	3200

ISO Coarse Dust  
2.0 g/m<sup>3</sup> Feed Rate  
25" H<sub>2</sub>O (6.2 kPa)  
Terminal Restriction  
per ISO 5011

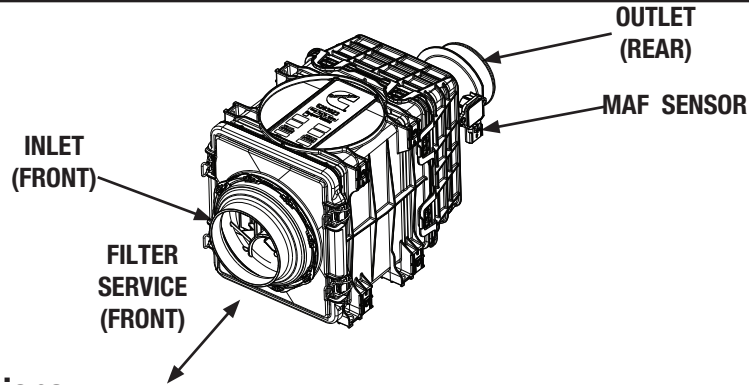

## Specifications

Specification	AH55592
Length, Overall	20.5" (521.0 mm)
Width, Overall	9.5" (241.3 mm)
Height, Overall	10.9" (277.4 mm)
Flow, Min. at 2" H <sub>2</sub> O (0.5 kPa) Restriction	133 CFM (3.8 m <sup>3</sup> /min)
Flow, Max. at 12" H <sub>2</sub> O (3.0 kPa) Restriction	346 CFM (9.8 m <sup>3</sup> /min)
Secondary Element	Yes
Housing Material	Glass-filled Polyamide
Pre-Cleaner	No
Inlet	Straight, 5.0" (Ø127.0 mm)
Outlet	Straight, 4.0" (Ø101.6 mm)
Filter Efficiency	≥ 99.90% per ISO 5011

Specifications Subject to change without notice.

## Dust Holding Capacity per Flow Rate

Specification	Non Aspirated	
	CFM	m <sup>3</sup> /min
Maximum Flow for 10 g/CFM (357.1 g/m <sup>3</sup> /min)	149	5.9
Maximum Flow for 25 g/CFM (892.9 g/m <sup>3</sup> /min)	N/A	N/A

## Dimensions

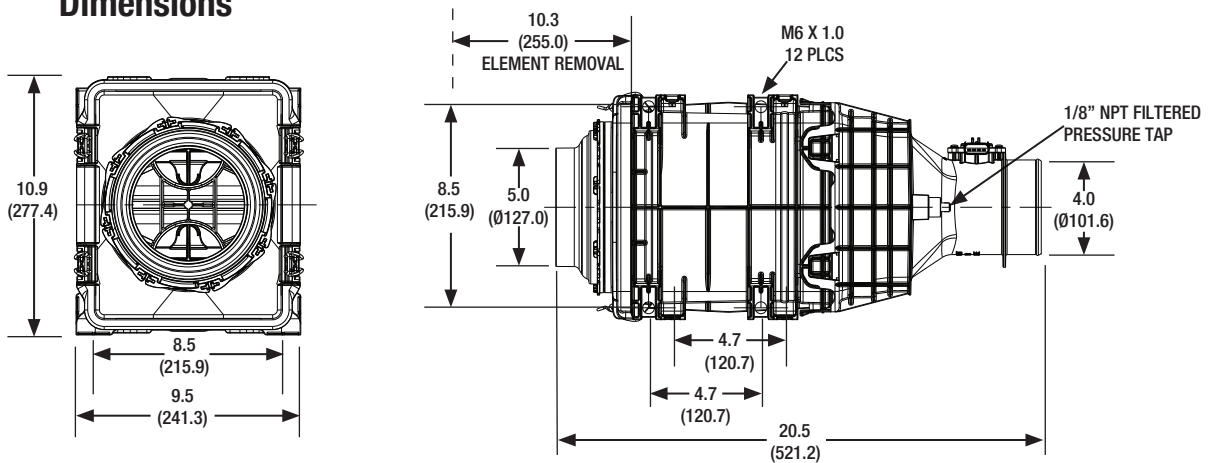

All dimensions are in inches (millimeters)

## Ordering Information

Air Cleaners	
Part Number	Description
AH55592	Direct Flow -Remote Pre-Cleaner -Front Inlet -With MAF Sensor

Service Parts	
Part Number	Description
AF55020	Primary Element
AF55312	Secondary Element
SP1054	Mass Airflow Sensor
SP1060	M6 Mounting Clips
SP1042	Front Service Cover

Optional Accessories	
Part Number	Description
3316658S	4" Band Clamp
3316660S	5" Band Clamp
3316608S	4" Hump Hose
3316610S	5" Hump Hose
3316568S	4" 90° Elbow
3316570S	5" 90° Elbow
3316618S	5" to 4" Hump Hose Reducer
3946329S	Restriction Indicator

Additional sizes/shapes may be available. Refer to the Cummins Filtration catalog or website.

## Performance

### System Restriction vs Flow Rate

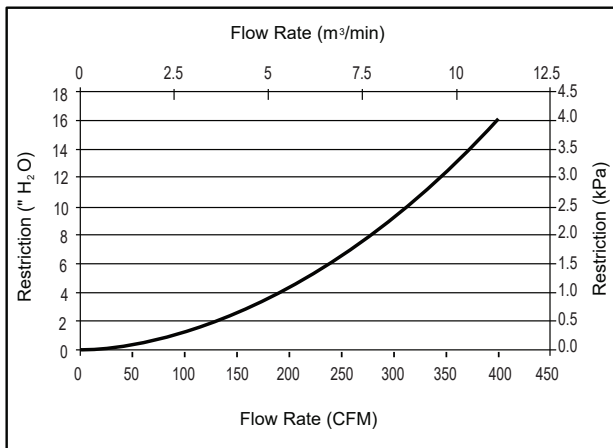

### System Capacity vs Flow Rate

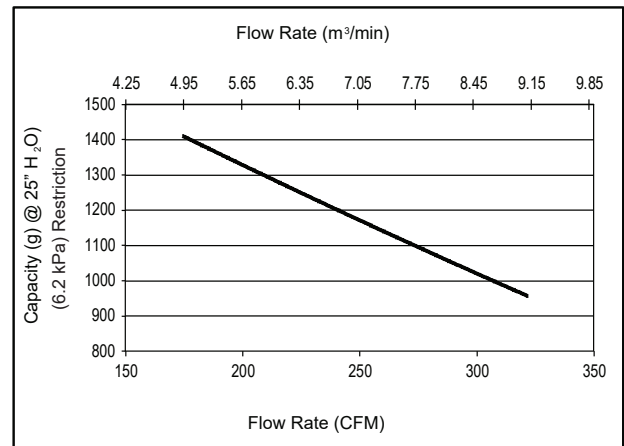

Restriction		Flow Rate		Typical Capacity at 25" H <sub>2</sub> O (6.2 kPa) of Terminal Restriction Non Aspirated (g)
in H <sub>2</sub> O	kPa	CFM	m³/min	
4	1.0	188	5.3	1366
6	1.5	236	6.6	1218
8	2.0	278	7.8	1090
10	2.5	314	8.9	981
12	3.0	346	9.8	889

ISO Fine Dust  
1.0 g/m<sup>3</sup> Feed Rate  
25" H<sub>2</sub>O (6.2 kPa)  
Terminal Restriction  
per ISO 5011



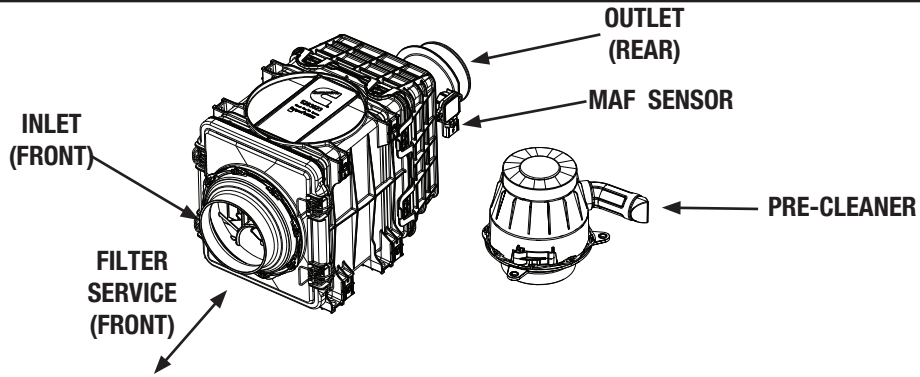

## Specifications

Specification	AK55681
Length, Overall	20.5" (521.0 mm)
Width, Overall	9.5" (241.3 mm)
Height, Overall	10.9" (277.4 mm)
Flow, Min. at 2" H <sub>2</sub> O (0.5 kPa) Restriction	133 CFM (3.8 m <sup>3</sup> /min)
Flow, Max. at 12" H <sub>2</sub> O (3.0 kPa) Restriction	308 CFM (8.7 m <sup>3</sup> /min)
Secondary Element	Yes
Housing Material	Glass-filled Polyamide
Pre-Cleaner	Remote
Inlet	Straight, 5.0" (Ø127.0 mm)
Outlet	Straight, 4.00" (Ø101.6 mm)
Filter Efficiency	≥ 99.90% per ISO 5011

Specifications Subject to change without notice.

## Dust Holding Capacity per Flow Rate

Specification	Non Aspirated	
	CFM	m <sup>3</sup> /min
Maximum Flow for 10 g/CFM (357.1 g/m <sup>3</sup> /min)	298*	8.4*
Maximum Flow for 25 g/CFM (892.9 g/m <sup>3</sup> /min)	152	4.3

\*Indicates maximum recommended flow rate.

## Dimensions

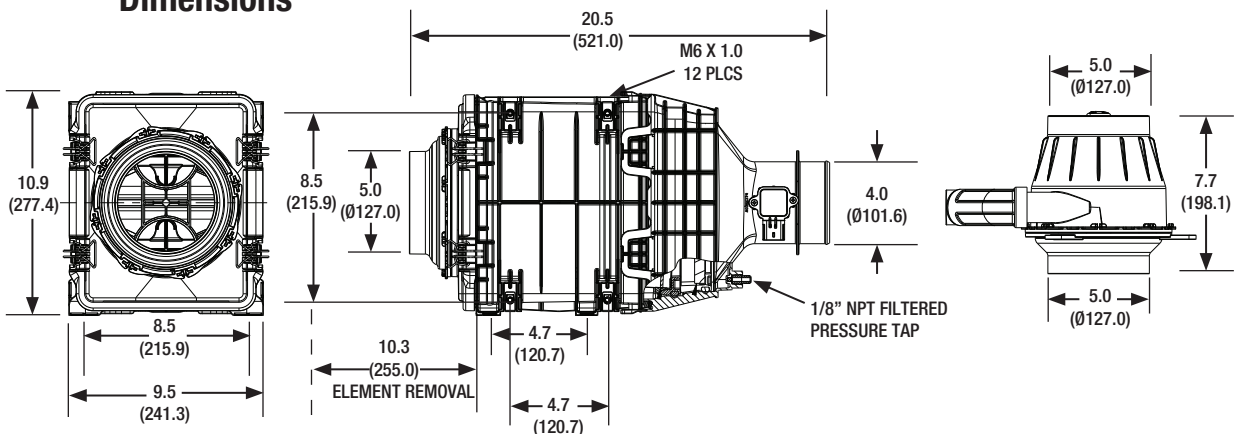

All dimensions are in inches (millimeters)

## Ordering Information

Air Cleaners		Service Parts		Optional Accessories	
Part Number	Description	Part Number	Description	Part Number	Description
AK55681	Direct Flow -Remote Pre-Cleaner -Front Inlet -With MAF Sensor	AF55020	Primary Element	3316658S	4" Band Clamp
		AF55312	Secondary Element	3316660S	5" Band Clamp
		SP1054	Mass Airflow Sensor	3316608S	4" Hump Hose
		AP15903	Pre-Cleaner	3316610S	5" Hump Hose
		SP1048	Dust Ejection Valve (DEV)	3316568S	4" 90° Elbow
		SP1060	M6 Mounting Clips	3316570S	5" 90° Elbow
		SP1042	Front Service Cover	3316618S	5" to 4" Hump Hose Reducer
				3946329S	Restriction Indicator

Additional sizes/shapes may be available.  
Refer to the Cummins Filtration catalog or website.

## Performance

### System Restriction vs Flow Rate

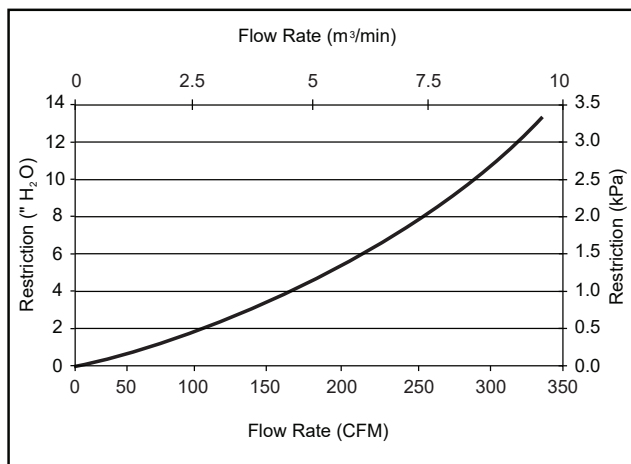

### System Capacity vs Flow Rate

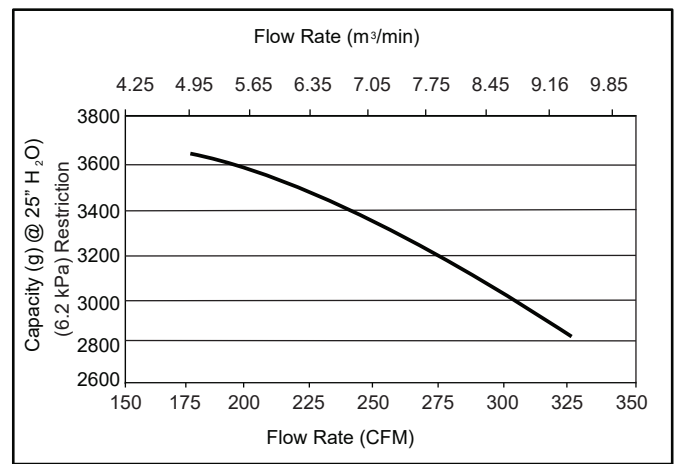

**Note:** These curves represent test data with limited data replicates. Data also reflects Pre-Cleaner as integrated.

Restriction		Flow Rate		Typical Capacity at 25" H <sub>2</sub> O (6.2 kPa) of Terminal Restriction	Typical Capacity at 30" H <sub>2</sub> O (6.2 kPa) of Terminal Restriction
in H <sub>2</sub> O	kPa	CFM	m³/min	Non Aspirated (g)	Non Aspirated (g)
4	1.0	170	4.8	3650	3730
6	1.5	213	6.0	3480	3590
8	2.0	248	7.0	3310	3500
10	2.5	280	7.9	3120	3440
12	3.0	308	8.7	2920	3390

ISO Coarse Dust  
2.0 g/m<sup>3</sup> Feed Rate  
25" H<sub>2</sub>O (6.2 kPa)  
Terminal Restriction  
per ISO 5011

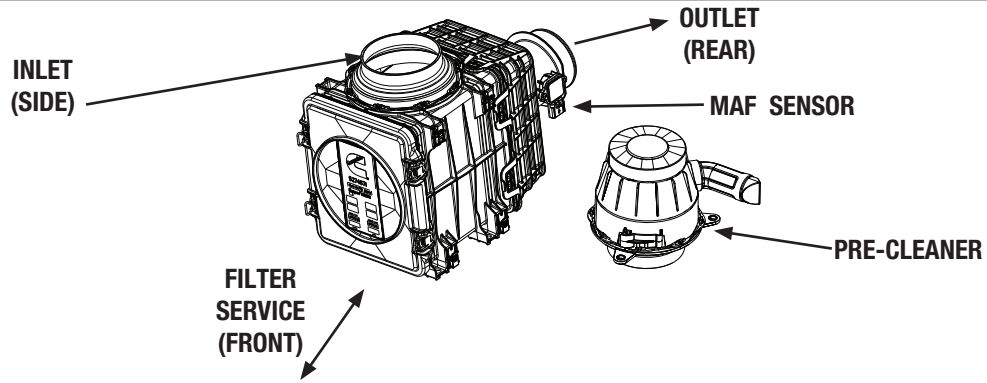

## Specifications

Specification	AK55682
Length, Overall	18.4" (469.2 mm)
Width, Overall	9.5" (241.3 mm)
Height, Overall	12.7" (322.8 mm)
Flow, Min. at 2" H <sub>2</sub> O (0.5 kPa) Restriction	120 CFM (3.3 m <sup>3</sup> /min)
Flow, Max. at 12" H <sub>2</sub> O (3.0 kPa) Restriction	308 CFM (8.7 m <sup>3</sup> /min)
Secondary Element	Yes
Housing Material	Glass-filled Polyamide
Pre-Cleaner	Remote
Inlet	90° to Outlet, 5.0" (Ø127.0 mm)
Outlet	Straight, 4.0" (Ø101.6 mm)
Filter Efficiency	≥ 99.90% per ISO 5011

Specifications Subject to change without notice.

## Dust Holding Capacity per Flow Rate

Specification	Non Aspirated	
	CFM	m <sup>3</sup> /min
Maximum Flow for 10 g/CFM (357.1 g/m <sup>3</sup> /min)	296*	8.4*
Maximum Flow for 25 g/CFM (892.9 g/m <sup>3</sup> /min)	152	4.3

\*Indicates maximum recommended flow rate.

## Dimensions

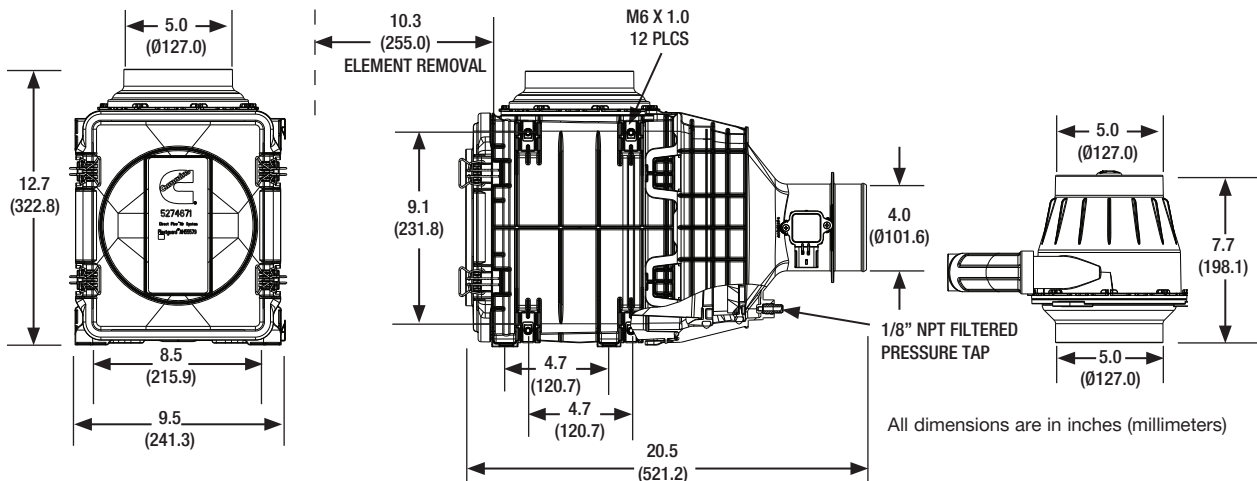

All dimensions are in inches (millimeters)

## Ordering Information

Air Cleaners	
Part Number	Description
AK55682	Direct Flow -Remote Pre-Cleaner -Front Inlet -With MAF Sensor

Service Parts	
Part Number	Description
AF55020	Primary Element
AF55312	Secondary Element
AP15903	Pre-Cleaner
SP1048	Dust Ejection Valve (DEV)
SP1060	M6 Mounting Clips
SP1041	Front Service Cover

Optional Accessories	
Part Number	Description
3316658S	4" Band Clamp
3316660S	5" Band Clamp
3316608S	4" Hump Hose
3316610S	5" Hump Hose
3316568S	4" 90° Elbow
3316570S	5" 90° Elbow
3316618S	5" to 4" Hump Hose Reducer
3946329S	Restriction Indicator

Additional sizes/shapes may be available.  
Refer to the Cummins Filtration catalog or website.

## Performance

### System Restriction vs Flow Rate

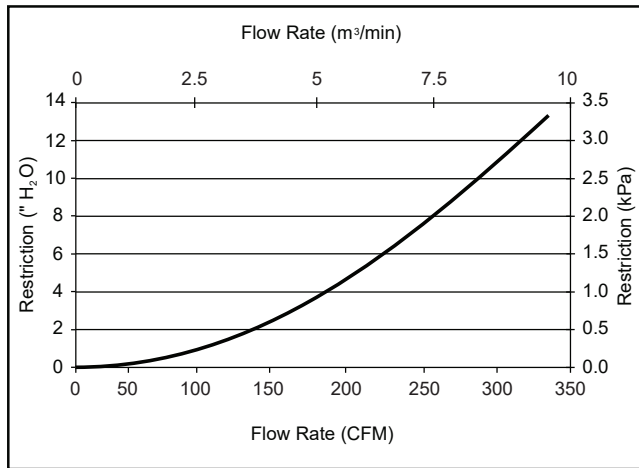

### System Capacity vs Flow Rate

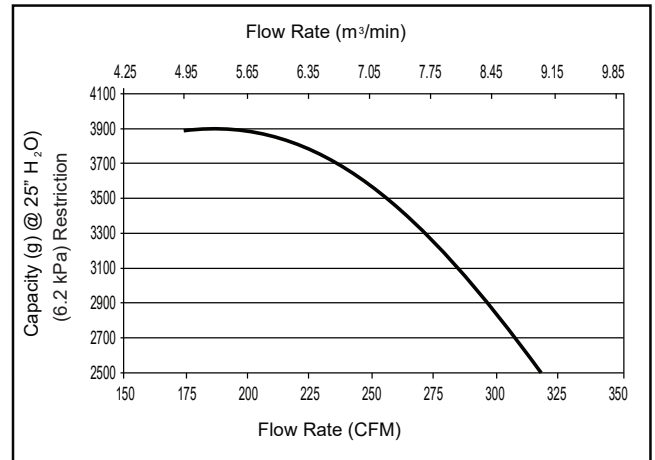

**Note:** Data reflects Pre-Cleaner as integrated.

Restriction		Flow Rate		Typical Capacity at 25" H <sub>2</sub> O (6.2 kPa) of Terminal Restriction	Typical Capacity at 30" H <sub>2</sub> O (6.2 kPa) of Terminal Restriction
in H <sub>2</sub> O	kPa	CFM	m <sup>3</sup> /min	Non Aspirated (g)	Non Aspirated (g)
4	1.0	165	4.6	3850	3970
6	1.5	210	5.9	3840	3960
8	2.0	248	7.0	3580	3790
10	2.5	280	7.9	3200	3520
12	3.0	308	8.7	2730	3200

ISO Coarse Dust  
2.0 g/m<sup>3</sup> Feed Rate  
25" H<sub>2</sub>O (6.2 kPa)  
Terminal Restriction  
per ISO 5011