

Specifications

Specification	AK55692
Length, Overall	20.5" (521.2 mm)
Width, Overall	10.9" (277.4 mm)
Height, Overall	9.5" (241.3 mm)
Flow, Min. at 2" H ₂ O (0.5 kPa) Restriction	145 CFM (4.1 m ³ /min)
Flow, Max. at 12" H ₂ O (3.0 kPa) Restriction	360 CFM (10.1 m ³ /min)
Secondary Element	Yes
Housing Material	Glass-filled Polyamide
Pre-Cleaner	Remote
Inlet	Straight, 5.0" (Ø127.0 mm)
Outlet	Straight, 4.0" (Ø101.6 mm)
Filter Efficiency	≥ 99.90% per ISO 5011

Specifications Subject to change without notice.

Dust Holding Capacity per Flow Rate

Specification	Non Aspirated	
	CFM	m ³ /min
Maximum Flow for 10 g/CFM (357.1 g/m ³ /min)	360.0*	10.0*
Maximum Flow for 25 g/CFM (892.9 g/m ³ /min)	188.0	5.3

*Indicates maximum recommended flow rate.

Dimensions

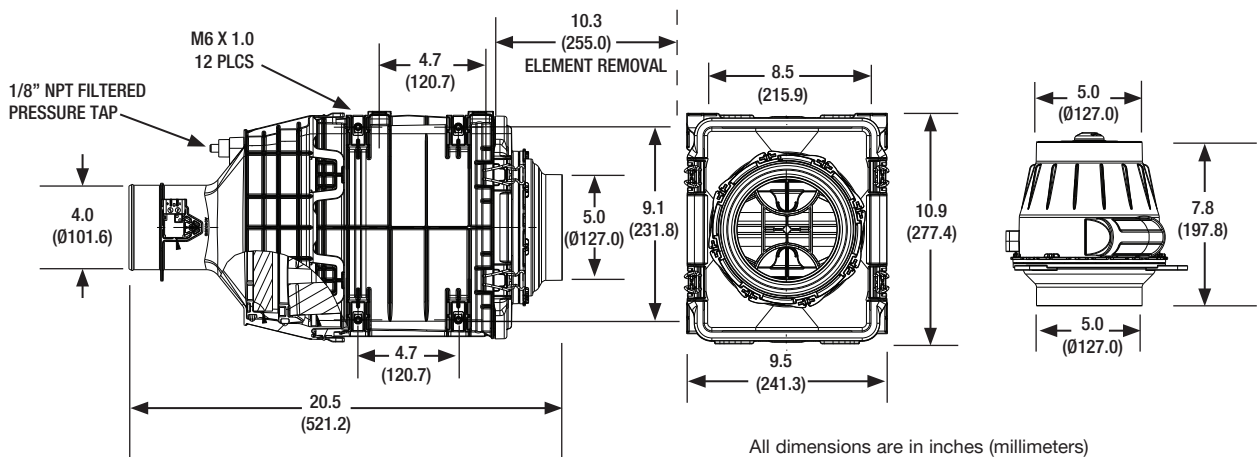

All dimensions are in inches (millimeters)

Ordering Information

Air Cleaners		Service Parts		Optional Accessories	
Part Number	Description	Part Number	Description	Part Number	Description
AK55692	Direct Flow -Remote Pre-Cleaner -Front Inlet -With TBAP Sensor	AF55020	Primary Element	3316658S	4" Band Clamp
		AF55320	Secondary Element	3316660S	5" Band Clamp
		AP15914	Pre-Cleaner	3316608S	4" Hump Hose
		AP15912	Pre-Cleaner Remote Adapter	3316610S	5" Hump Hose
		SP1048	Dust Ejection Valve (DEV)	3316568S	4" 90° Elbow
		SP1060	M6 Mounting Clips	3316570S	5" 90° Elbow
		SP1042	Front Service Cover	3316618S	5" to 4" Hump Hose Reducer
				3946329S	Restriction Indicator

Additional sizes/shapes may be available.
Refer to the Cummins Filtration catalog or website.

Performance

System Restriction vs Flow Rate

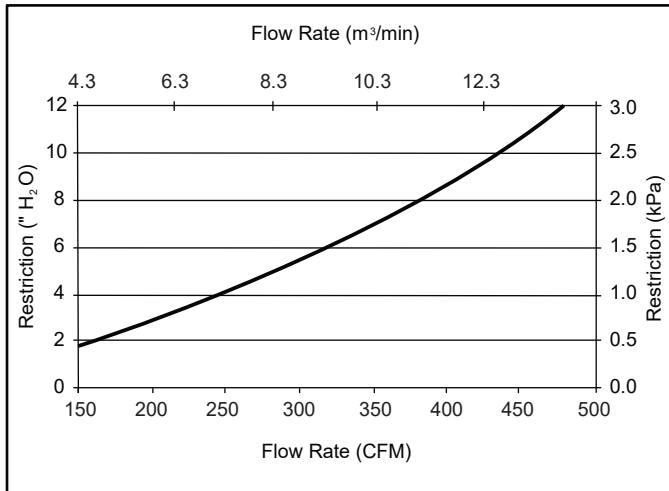

System Capacity vs Flow Rate

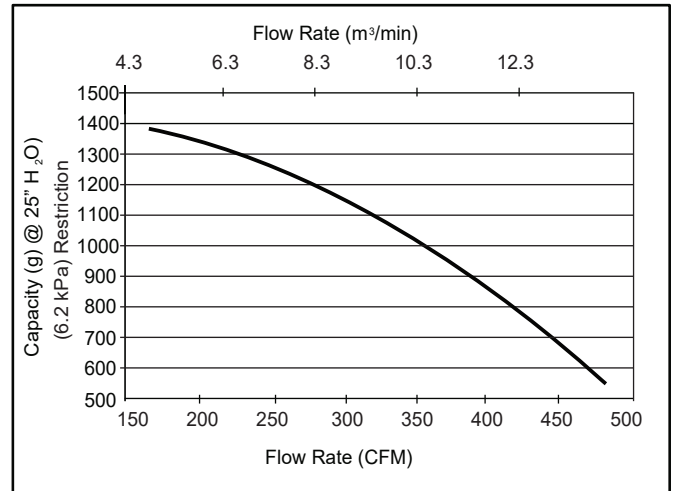

Restriction		Flow Rate		Typical Capacity at 25" H ₂ O (6.2 kPa) of Terminal Restriction
in H ₂ O	kPa	CFM	m³/min	Non Aspirated (g)
4	1.0	210	5.9	4575
6	1.5	260	7.4	4350
8	2.0	300	8.5	4090
10	2.5	338	9.6	3800
12	3.0	360	10.2	3530

ISO Coarse Dust
2.0 g/m³ Feed Rate
25" H₂O (6.2 kPa)
Terminal Restriction
per ISO 5011

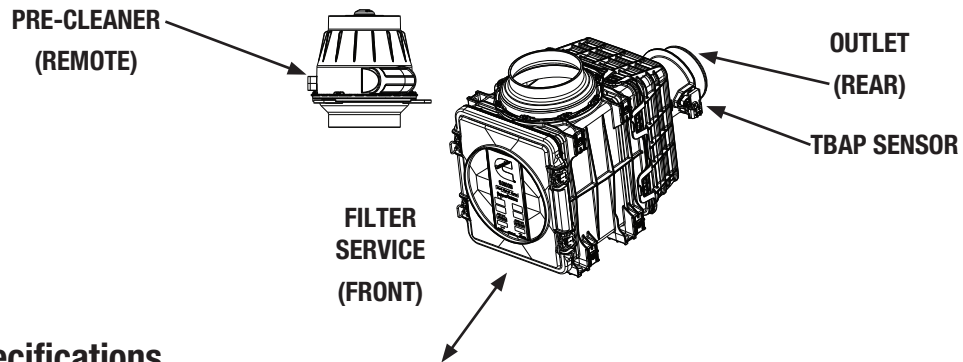

Specifications

Specification	AK55693
Length, Overall	18.4" (469.2 mm)
Width, Overall	9.5" (241.3 mm)
Height, Overall	12.7" (322.8 mm)
Flow, Min. at 2" H ₂ O (0.5 kPa) Restriction	145 CFM (4.1 m ³ /min)
Flow, Max. at 12" H ₂ O (3.0 kPa) Restriction	367 CFM (10.4 m ³ /min)
Secondary Element	Yes
Housing Material	Glass-filled Polyamide
Pre-Cleaner	No
Inlet	90° to Outlet, 5.0" (Ø127.0 mm)
Outlet	Straight 4.0" (Ø101.6 mm)
Filter Efficiency	≥ 99.90% per ISO 5011

Specifications Subject to change without notice.

Dust Holding Capacity per Flow Rate

Specification	Non Aspirated	
	CFM	m ³ /min
Maximum Flow for 10 g/CFM (357.1 g/m ³ /min)	367*	10.4*
Maximum Flow for 25 g/CFM (892.9 g/m ³ /min)	205	5.7

*Indicates maximum recommended flow rate.

Dimensions

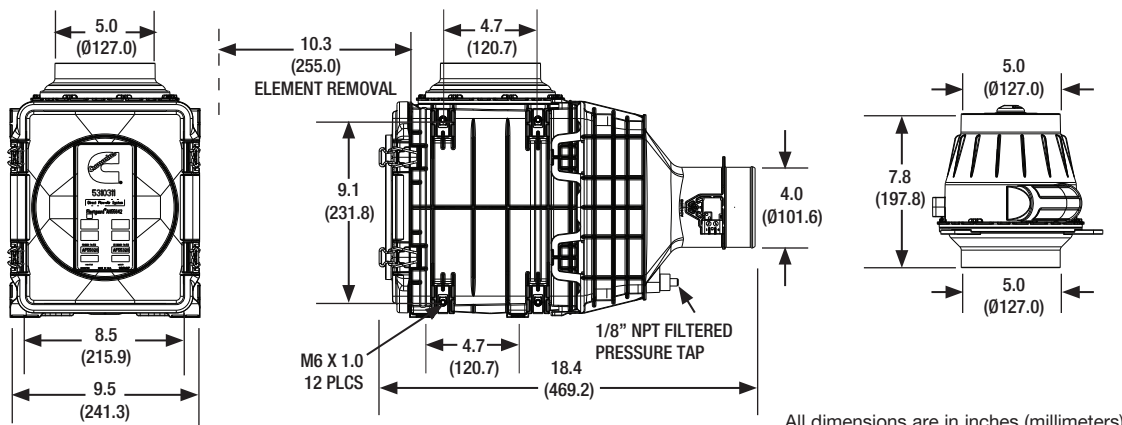

All dimensions are in inches (millimeters)

Ordering Information

Air Cleaners	
Part Number	Description
AK55693	Direct Flow -Remote Pre-Cleaner -Front Inlet -With TBAP Sensor

Service Parts	
Part Number	Description
AF55020	Primary Element
AF55320	Secondary Element
AP15914	Pre-Cleaner
AP15912	Pre-Cleaner Remote Adapter
SP1048	Dust Ejection Valve (DEV)
SP1060	M6 Mounting Clips
SP1041	Front Service Cover

Optional Accessories	
Part Number	Description
3316658S	4" Band Clamp
3316660S	5" Band Clamp
3316608S	4" Hump Hose
3316610S	5" Hump Hose
3316568S	4" 90° Elbow
3316570S	5" 90° Elbow
3316618S	5" to 4" Hump Hose Reducer
3946329S	Restriction Indicator

Additional sizes/shapes may be available. Refer to the Cummins Filtration catalog or website.

Performance

System Restriction vs Flow Rate

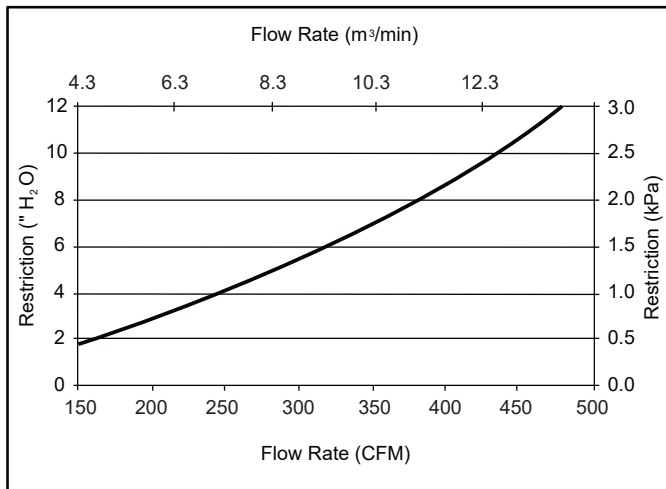

System Capacity vs Flow Rate

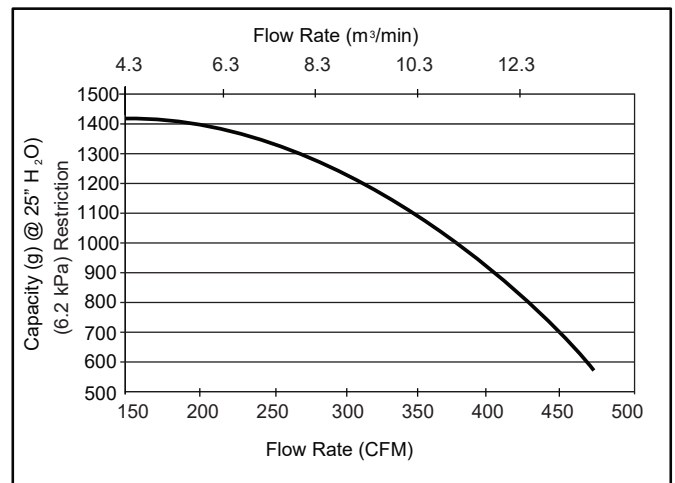

*Data reflects the Pre-Cleaner as Integrated.

Restriction		Flow Rate		Typical Capacity at 25" H ₂ O (6.2 kPa) of Terminal Restriction
in H ₂ O	kPa	CFM	m³/min	Non Aspirated (g)
4	1.0	210	5.9	5130
6	1.5	257	7.3	4750
8	2.0	297	8.4	4350
10	2.5	335	9.5	3900
12	3.0	367	10.4	3550

ISO Coarse Dust
2.0 g/m³ Feed Rate
25" H₂O (6.2 kPa)
Terminal Restriction
per ISO 5011

DF390 TBAP Series

Direct Flow Air Cleaners

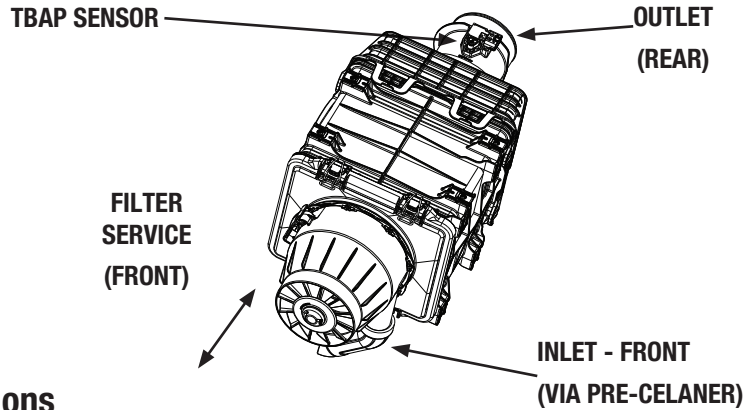

Specifications

Specification	AK55694
Length, Overall	24.7" (629.0 mm)
Width, Overall	10.9" (277.4 mm)
Height, Overall	9.5" (241.3 mm)
Flow, Min. at 2" H ₂ O (0.5 kPa) Restriction	145 CFM (4.1 m ³ /min)
Flow, Max. at 12" H ₂ O (3.0 kPa) Restriction	360 CFM (10.2 m ³ /min)
Secondary Element	Yes
Housing Material	Glass-filled Polyamide
Pre-Cleaner	Integrated
Inlet	Straight - via Pre-cleaner 5.0" (Ø127.0 mm)
Outlet	Straight 4.0" (Ø101.6 mm)
Filter Efficiency	≥ 99.90% per ISO 5011

Specifications Subject to change without notice.

Dust Holding Capacity per Flow Rate

Specification	Non Aspirated	
	CFM	m ³ /min
Maximum Flow for 10 g/CFM (357.1 g/m ³ /min)	360*	10.2*
Maximum Flow for 25 g/CFM (892.9 g/m ³ /min)	188	5.3

*Indicates maximum recommended flow rate.

Dimensions

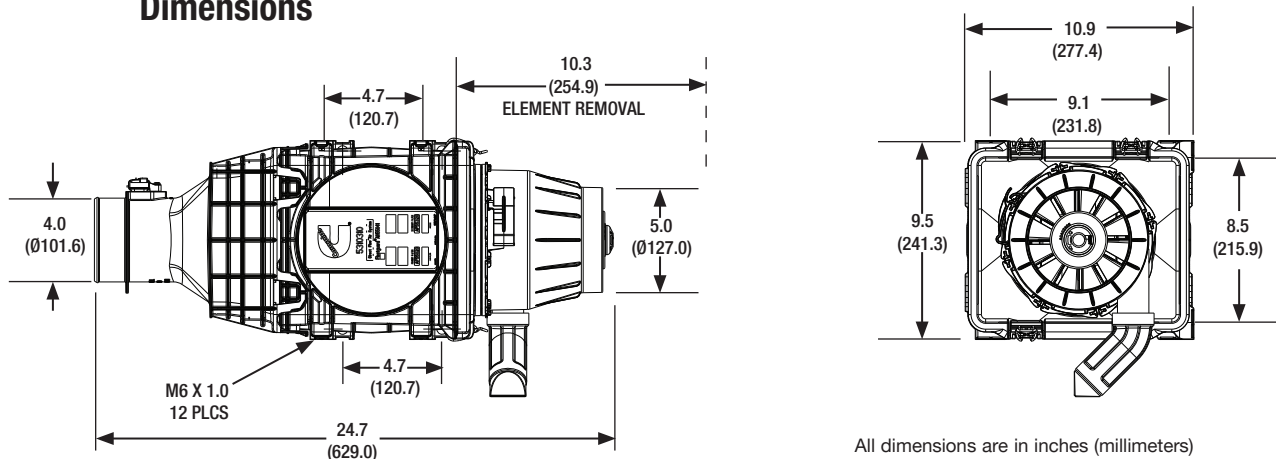

All dimensions are in inches (millimeters)

Ordering Information

Air Cleaners	
Part Number	Description
AK55694	Direct Flow -Front Inlet -With TBAP Sensor -Integrated Pre-Cleaner

Service Parts	
Part Number	Description
AF55020	Primary Element
AF55320	Secondary Element
SP1048	Dust Ejection valve (DEV)
SP1060	M6 Mounting Clips
SP1042	Front Service Cover
AP15914	Pre-Cleaner

Optional Accessories	
Part Number	Description
3316658S	4" Band Clamp
3316660S	5" Band Clamp
3316608S	4" Hump Hose
3316610S	5" Hump Hose
3316568S	4" 90° Elbow
3316570S	5" 90° Elbow
3316618S	5" to 4" Hump Hose Reducer
3946329S	Restriction Indicator

Additional sizes/shapes may be available. Refer to the Cummins Filtration catalog or website.

Performance

System Restriction vs Flow Rate

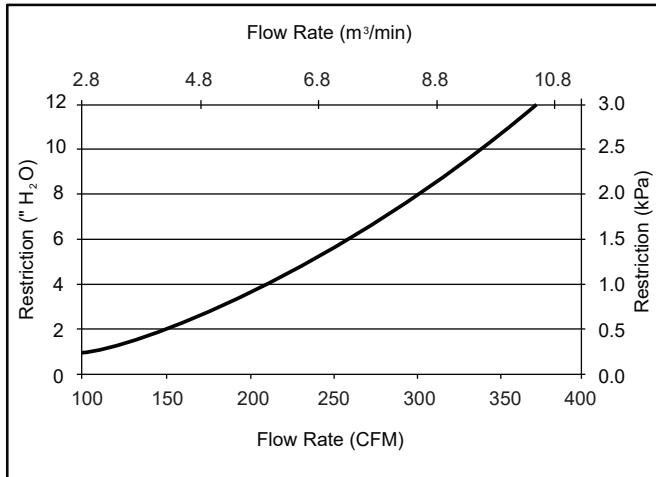

System Capacity vs Flow Rate

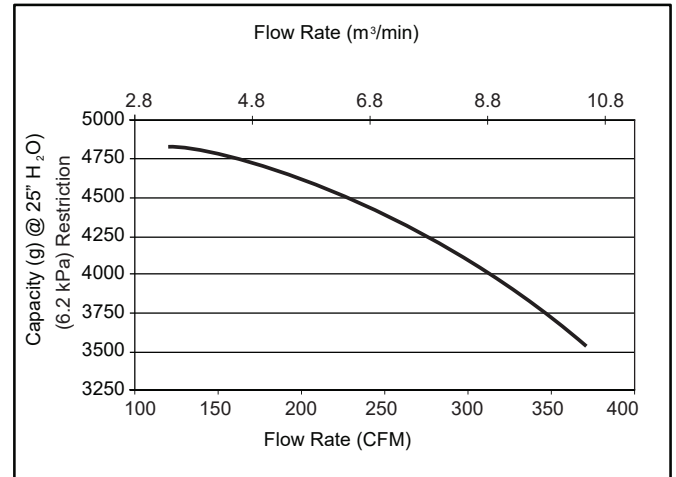

Restriction		Flow Rate		Typical Capacity at 25" H ₂ O (6.2 kPa) of Terminal Restriction
in H ₂ O	kPa	CFM	m³/min	Non Aspirated (g)
4	1.0	210	5.9	4575
6	1.5	260	7.4	4350
8	2.0	300	8.5	4090
10	2.5	338	9.6	3800
12	3.0	360	10.2	3530

ISO Coarse Dust
2.0 g/m³ Feed Rate
25" H₂O (6.2 kPa)
Terminal Restriction
per ISO 5011

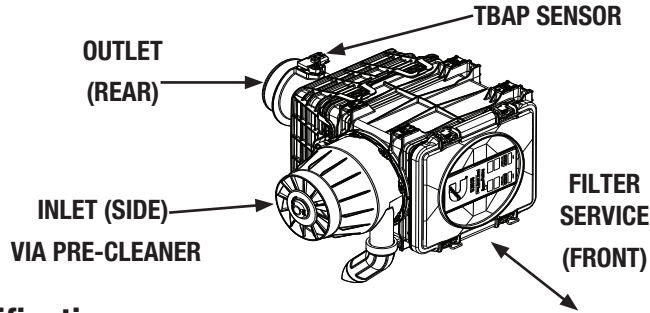

Specifications

Specification	AK55695
Length, Overall	18.4" (469.2 mm)
Width, Overall	16.9" (430.0 mm)
Height, Overall	9.5" (241.3 mm)
Flow, Min. at 2" H ₂ O (0.5 kPa) Restriction	145 CFM (4.1 m ³ /min)
Flow, Max. at 12" H ₂ O (3.0 kPa) Restriction	367 CFM (10.4 m ³ /min)
Secondary Element	Yes
Housing Material	Glass-filled Polyamide
Pre-Cleaner	Integrated
Inlet	90° to Outlet - via Pre-Cleaner 5.0" (Ø127.0 mm)
Outlet	Straight 4.0" (Ø101.6 mm)
Filter Efficiency	≥ 99.90% per ISO 5011

Specifications Subject to change without notice.

Dust Holding Capacity per Flow Rate

Specification	Non Aspirated	
	CFM	m ³ /min
Maximum Flow for 10 g/CFM (357.1 g/m ³ /min)	367*	10.4*
Maximum Flow for 25 g/CFM (892.9 g/m ³ /min)	205	5.7

*Indicates maximum recommended flow rate.

Dimensions

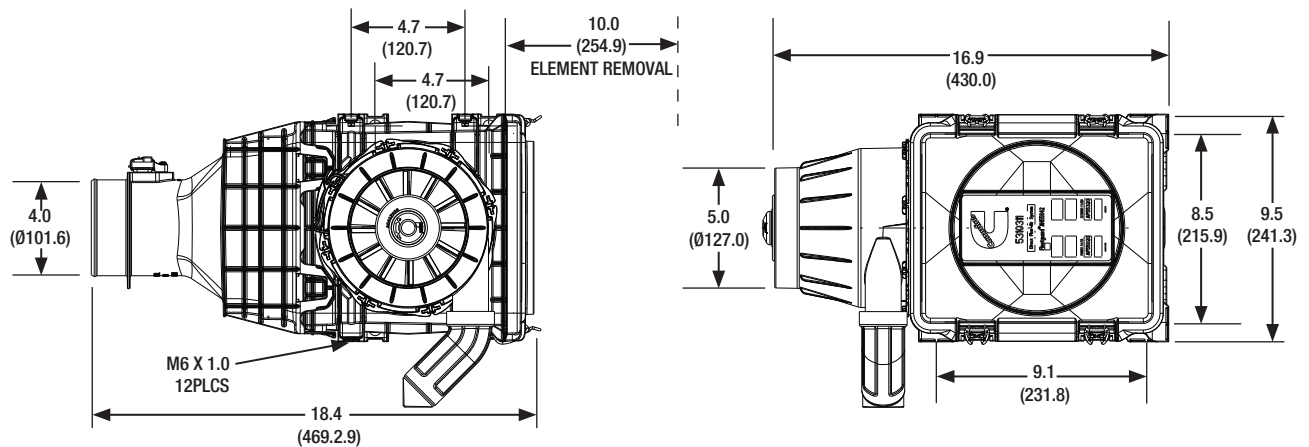

All dimensions are in inches (millimeters)

Ordering Information

Air Cleaners	
Part Number	Description
AH55695	Direct Flow -Integrated Pre-Cleaner -Front Inlet -With TBAP Sensor

Service Parts	
Part Number	Description
AF55020	Primary Element
AF55320	Secondary Element
SP1048	Dust Ejection Valve (DEV)
SP1060	M6 Mounting Clips
SP1041	Front Service Cover
AP15914	Pre-Cleaner

Optional Accessories	
Part Number	Description
3316658S	4" Band Clamp
3316660S	5" Band Clamp
3316608S	4" Hump Hose
3316610S	5" Hump Hose
3316568S	4" 90° Elbow
3316570S	5" 90° Elbow
3316618S	5" to 4" Hump Hose Reducer
3946329S	Restriction Indicator

Additional sizes/shapes may be available.
Refer to the Cummins Filtration catalog or website.

Performance

System Restriction vs Flow Rate

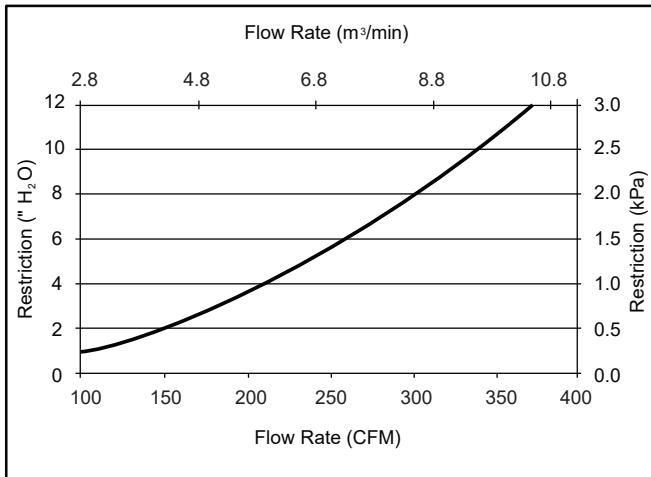

System Capacity vs Flow Rate

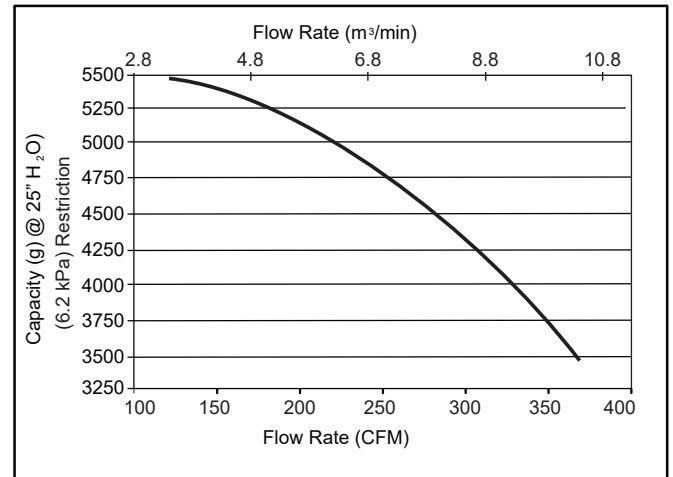

Restriction		Flow Rate		Typical Capacity at 25" H ₂ O (6.2 kPa) of Terminal Restriction
in H ₂ O	kPa	CFM	m³/min	Non Aspirated (g)
4	1.0	210	5.9	5130
6	1.5	257	7.3	4750
8	2.0	297	8.4	4350
10	2.5	335	9.5	3900
12	3.0	367	10.4	3550

ISO Coarse Dust
2.0 g/m³ Feed Rate
25" H₂O (6.2 kPa)
Terminal Restriction
per ISO 5011

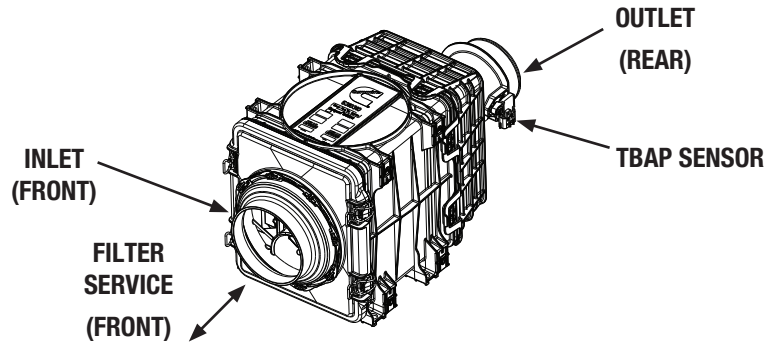

Specifications

Specification	AH55641
Length, Overall	20.5" (521.0 mm)
Width, Overall	9.5" (241.3 mm)
Height, Overall	10.9" (277.4 mm)
Flow, Min. at 2" H ₂ O (0.5 kPa) Restriction	175 CFM (4.9 m ³ /min)
Flow, Max. at 12" H ₂ O (3.0 kPa) Restriction	475 CFM (13.5 m ³ /min)
Secondary Element	Yes
Housing Material	Glass-filled Polyamide
Pre-Cleaner	No
Inlet	Straight, 5.0" (Ø127.0 mm)
Outlet	Straight, 4.0" (Ø101.6 mm)
Filter Efficiency	≥ 99.90% per ISO 5011

Specifications Subject to change without notice.

Dust Holding Capacity per Flow Rate

Specification	Non Aspirated	
	CFM	m ³ /min
Maximum Flow for 10 g/CFM (357.1 g/m ³ /min)	175	4.9
Maximum Flow for 25 g/CFM (892.9 g/m ³ /min)	N/A	N/A

Dimensions

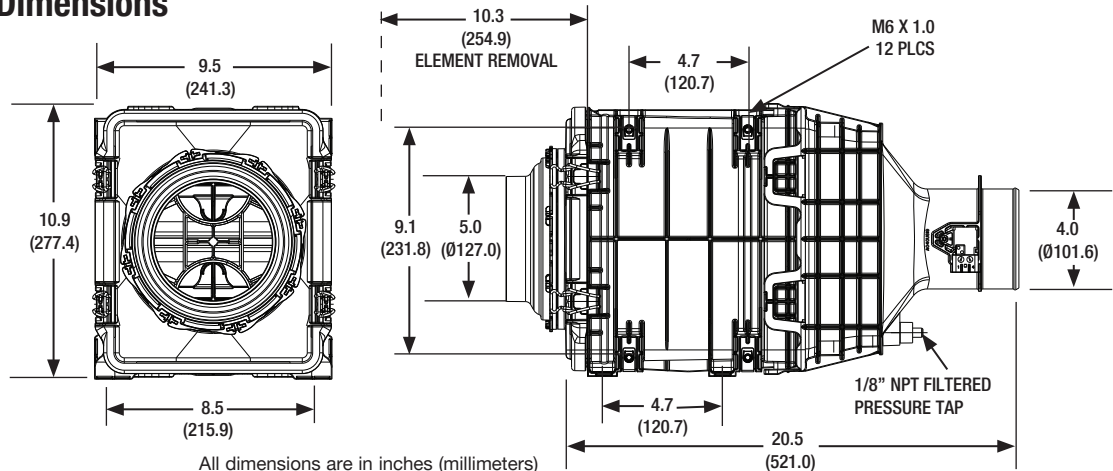

Ordering Information

Air Cleaners	
Part Number	Description
AH55641	Direct Flow -Front Inlet -With TBAP Sensor

Service Parts	
Part Number	Description
AF55020	Primary Element
AF55320	Secondary Element
SP1042	Front Service Cover
SP1060	M6 Mounting Clips

Optional Accessories	
Part Number	Description
3316658S	4" Band Clamp
3316660S	5" Band Clamp
3316608S	4" Hump Hose
3316610S	5" Hump Hose
3316568S	4" 90° Elbow
3316570S	5" 90° Elbow
3316618S	5" to 4" Hump Hose Reducer
3946329S	Restriction Indicator

Additional sizes/shapes may be available.
Refer to the Cummins Filtration catalog or website.

Performance

System Restriction vs Flow Rate

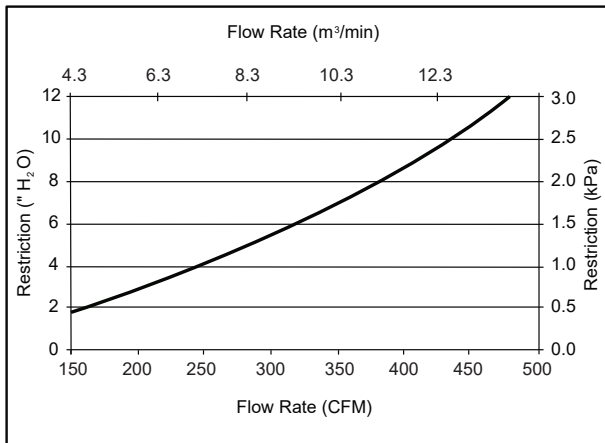

System Capacity vs Flow Rate

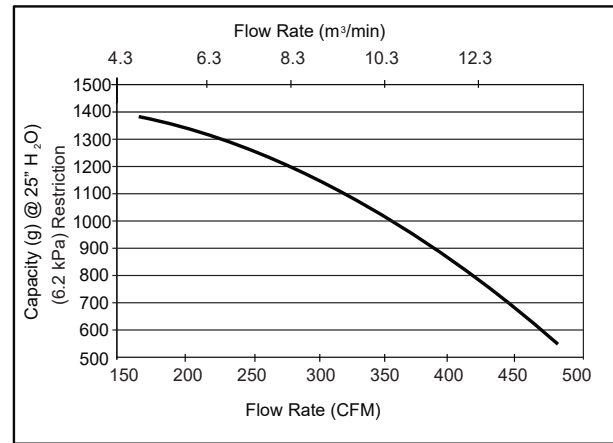

Restriction		Flow Rate		Typical Capacity at 25" H ₂ O (6.2 kPa) of Terminal Restriction
in H ₂ O	kPa	CFM	m³/min	Non Aspirated (g)
4	1.0	260	7.4	1325
6	1.5	330	9.3	1150
8	2.0	382	10.8	988
10	2.5	433	12.3	813
12	3.0	475	13.2	638

ISO Fine Dust
1.0 g/m³ Feed Rate
25" H₂O (6.2 kPa)
Terminal Restriction
per ISO 5011

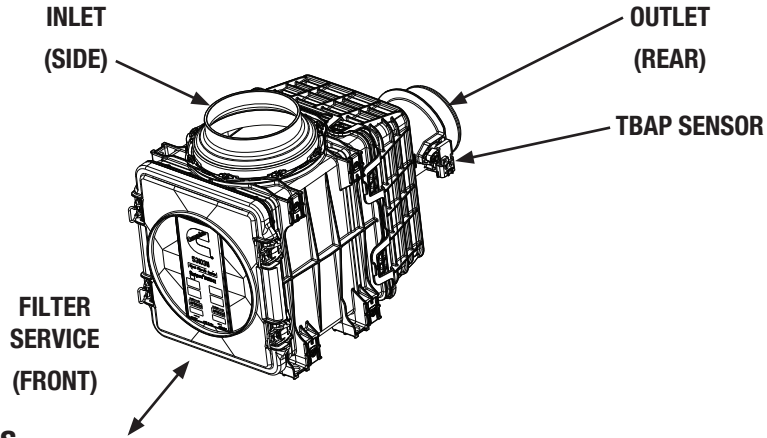

Specifications

Specification	AH55642
Length, Overall	18.5" (469.2 mm)
Width, Overall	9.5" (241.3 mm)
Height, Overall	12.7" (322.8 mm)
Flow, Min. at 2" H ₂ O (0.5 kPa) Restriction	175 CFM (4.9 m ³ /min)
Flow, Max. at 12" H ₂ O (3.0 kPa) Restriction	470 CFM (13.3 m ³ /min)
Secondary Element	Yes
Housing Material	Glass-filled Polyamide
Pre-Cleaner	No
Inlet	90° to Outlet, 5.0" (Ø127.0 mm)
Outlet	Straight 4.0" (101.6 mm)
Filter Efficiency	≥ 99.90% per ISO 5011

Specifications Subject to change without notice.

Dust Holding Capacity per Flow Rate

Specification	Non Aspirated	
	CFM	m ³ /min
Maximum Flow for 10 g/CFM (357.1 g/m ³ /min)	175	4.9
Maximum Flow for 25 g/CFM (892.9 g/m ³ /min)	N/A	N/A

* Requires Pre-Cleaner (Optional)

Dimensions

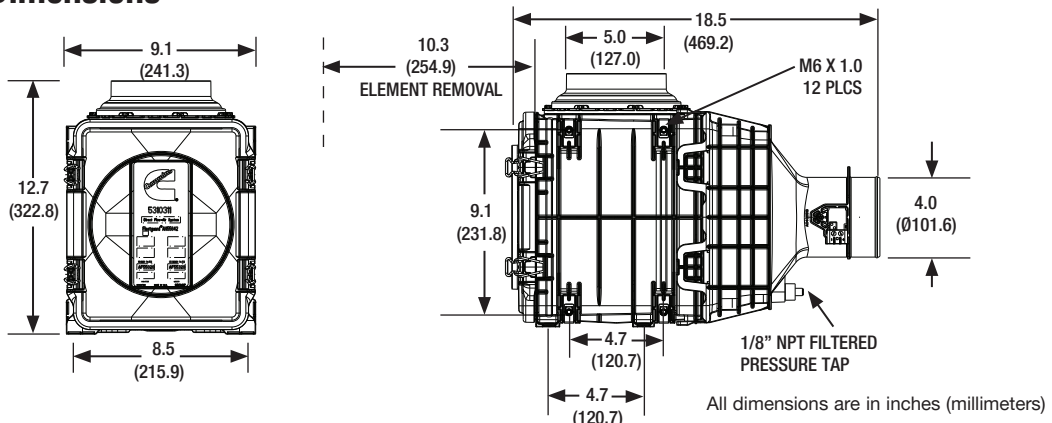

All dimensions are in inches (millimeters)

Ordering Information

Air Cleaners		Service Parts		Optional Accessories	
Part Number	Description	Part Number	Description	Part Number	Description
AH55642	Direct Flow -Side Inlet -With TBAP Sensor	AF55030	Primary Element	3316658S	4" Band Clamp
		AF55321	Secondary Element	3316660S	5" Band Clamp
		SP1080	Front Service Cover	3316608S	4" Hump Hose
		SP1060	M6 Mounting Clips	3316610S	5" Hump Hose
				3316568S	4" 90° Elbow
				3316570S	5" 90° Elbow
				3316618S	5" to 4" Hump Hose Reducer
				3946329S	Restriction Indicator

Additional sizes/shapes may be available.
Refer to the Cummins Filtration catalog or website.

Performance

System Restriction vs Flow Rate

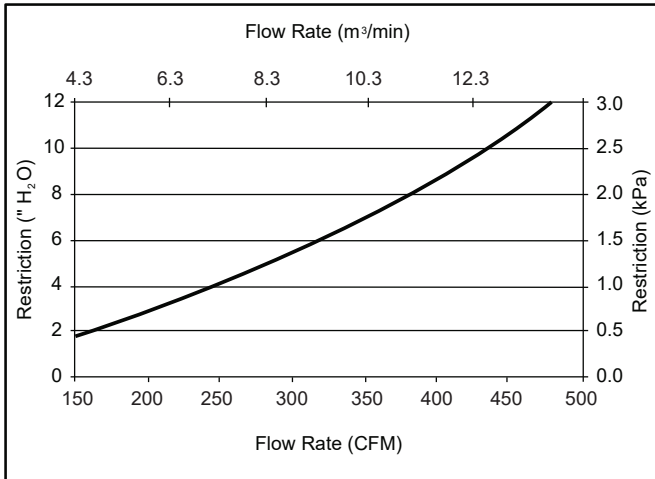

System Capacity vs Flow Rate

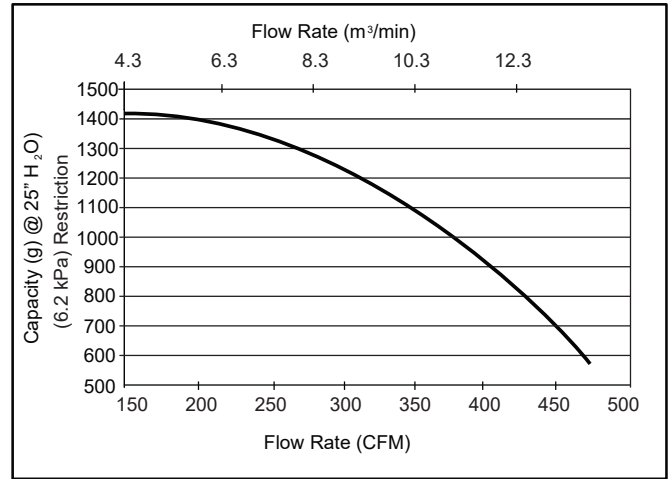

Restriction		Flow Rate		Typical Capacity at 25" H ₂ O (6.2 kPa) of Terminal Restriction
in H ₂ O	kPa	CFM	m³/min	Non Aspirated (g)
4	1.0	260	7.4	1325
6	1.5	325	9.2	1175
8	2.0	380	10.8	988
10	2.5	430	12.2	775
12	3.0	470	13.3	575

ISO Fine Dust
1.0 g/m³ Feed Rate
25" H₂O (6.2 kPa)
Terminal Restriction
per ISO 5011