



ASFA "S" Worm-Drive Clip (Black Finish)

Thanks to the exclusive design of the housing, the ASFA "S" W3 hose clip has excellent performance while being at the same time very compact.

The cold-formed stamped band thread, smoothed on the underside, combined with the beveled band edges protects the hose from any damage.

The ASFA "S" W3 hose clip complies fully with the DIN 3017 norm and also with the RoHs directive EU 2002/95/EC dated 1st July 2006.

The special black finish gives added corrosion resistance and makes this clip very popular in automotive and defense applications, as well as in the manufacture of agricultural and construction machinery.

* The maximum application pressure can vary depending on the type of hose used and the geometry of the coupling.
Patented Worldwide.

W3

ASFA "S" W3 Worm-Drive Clip (12mm bandwidth)

Application Ø	Part n° W3	L max.	s + 0,1 0	h max.	a -0,2	b Max.	Max. Values* Torque (Nm)	Max. Values* Pressure (Bars)	Box Quantity (MOQ)	Packing	
mm	inches										
16-27	5/8-1-1/16	73016206	29,6	0,8	11	12,2	18,8	4,2	45	50	400
20-32	25/32-1-1/4	73016214	29,6	0,8	11	12,2	18,8	5,2	45	50	400
25-40	1-1-9/16	73016222	29,6	0,8	11	12,2	18,8	5,2	40	50	400
30-45	1-3/16-1-3/4	73016230	29,6	0,8	11	12,2	18,8	5,2	35	50	400
32-50	1-1/4-1-31/32	73016249	29,6	0,8	11	12,2	18,8	6,0	35	50	400
40-60	1-9/16-2-3/8	73016257	29,6	0,8	11	12,2	18,8	6,0	30	50	400
50-70	1-31/32-2-3/4	73016265	31,6	0,8	11	12,2	18,8	6,8	25	50	400
60-80	2-3/8-3-1/8	73016273	31,6	0,8	11	12,2	18,8	6,8	20	50	50

W3 Screw: Stainless steel (AISI-430) Band and housing: Stainless steel X6Cr-17 (DIN 1.4016) (AISI-430) Finish: Black

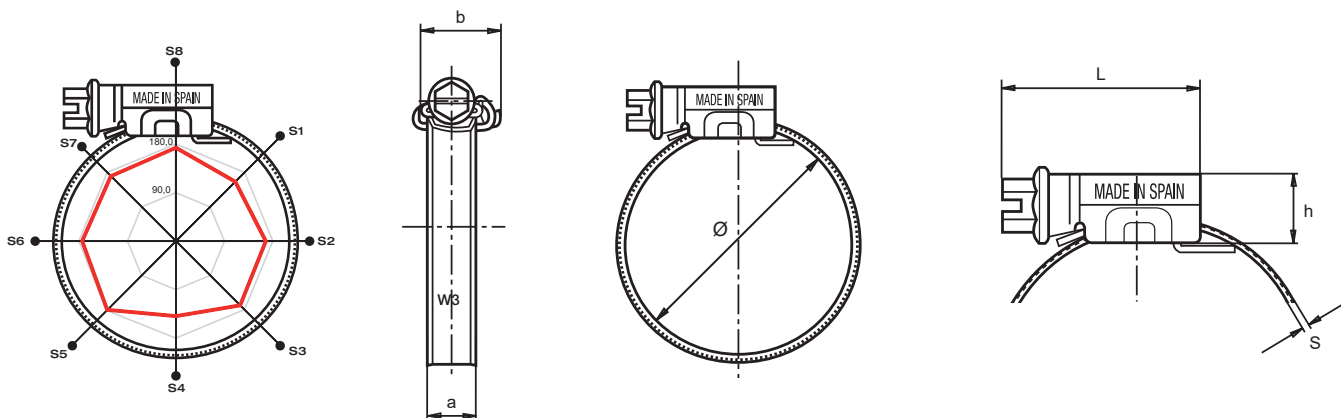

Polar Diagram

Sectors	S1	S2	S3	S4	S5	S6	S7	S8
5 Nm	156,0	166,9	168,7	139,2	180,4	173,9	170,7	173,2

Torque / Efficiency [Nm / daN]



Available Through:
BORSERINI SRL
 Via N. Sauro, 1
 I-23100 Sondrio SO
 Ph. +39 0342 209200 E-mail: info@borserini.it