



## ASFA "L" Worm-Drive Clip

Thanks to the exclusive design of the housing, the ASFA "L" W2 hose clip has excellent performance while being at the same time very compact.

The cold-formed stamped band thread, smoothed on the underside, combined with the beveled band edges protects the hose from any damage.

The ASFA "L" W2 hose clip complies fully with the DIN 3017 norm and also with the RoHs directive EU 2002/95/EC dated 1st July 2006. This clip is ideal for general industrial applications.

\* The maximum application pressure can vary depending on the type of hose used and the geometry of the coupling. **Patented Worldwide.**

**W2**

### ASFA "L" W2 Worm-Drive Clip (9mm bandwidth)

Application Ø		Part n° W2	L max.	s + 0,1 0	h max.	a + 0,3 a - 0,2	b max.	Max. Values* Torque (Nm)	Max. Values* Pressure (Bars)	Box Quantity (MOQ)	Packing
mm	inches										
8-12	5/16-15/32	03016508	17,5	0,65	8,4	7	10,9	1,5	30	200	1600
8-16	5/16-5/8	03016516	22,1	0,65	10,5	9	14,0	3,0	45	200	800
12-22	15/32-7/8	03016524	22,1	0,65	10,5	9	14,0	3,0	45	200	800
16-27	5/8-1-1/16	03016532	23,6	0,75	10,5	9	14,0	3,5	42	200	800
20-32	25/32-1-1/4	03016540	23,6	0,75	10,5	9	14,0	3,5	36	200	800
25-40	1-1-9/16	03016559	25,6	0,75	10,5	9	14,0	4,0	32	100	800
30-45	1-3/16-1-3/4	03016567	25,6	0,75	10,5	9	14,0	4,0	28	100	800
32-50	1-1/4-1-31/32	03016575	25,6	0,75	10,5	9	14,0	4,0	24	100	800
40-60	1-9/16-2-3/8	03016583	25,6	0,75	10,5	9	14,0	4,0	19	100	400
50-70	1-31/32-2-3/4	03016591	26,6	0,75	10,5	9	14,0	4,0	17	100	100
60-80	2-3/8-3-1/8	03016604	26,6	0,75	10,5	9	14,0	4,0	15	100	100
70-90	2-3/4-3-1/2	03016612	26,6	0,75	10,5	9	14,0	4,0	13	50	400
80-100	3-1/8-3-15/16	03016620	26,6	0,75	10,5	9	14,0	4,0	11	50	400
90-110	3-1/2-4-5/16	03016639	26,6	0,75	10,5	9	14,0	4,0	10	25	200
100-120	3-15/16-4-23/32	03016647	26,6	0,75	10,5	9	14,0	4,0	9	25	200
110-130	4-5/16-5-1/8	03016655	26,6	0,75	10,5	9	14,0	4,0	8	25	25
120-140	4-23/32-5-1/2	03016663	26,6	0,75	10,5	9	14,0	4,0	7	25	25
130-150	5-1/8-5-29/32	03016671	26,6	0,75	10,5	9	14,0	4,0	6	25	25
140-160	5-1/2-6-5/16	03016680	26,6	0,75	10,5	9	14,0	4,0	5	25	25

**W2 Screw:** Qst 36-3 Mild steel (DIN 1.0213) Silver-white Cr3 Zinc-Plated (AISI-430)

**Band and Housing:** X6Cr17 Stainless steel (DIN 1.4016)

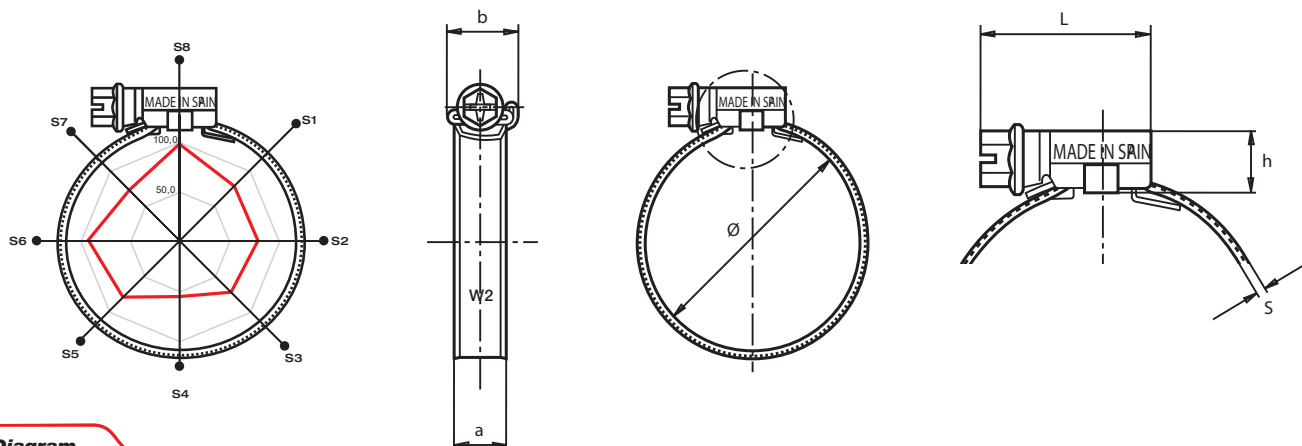

**Polar Diagram**

● Sectors	S1	S2	S3	S4	S5	S6	S7	S8
— 4 Nm	74,2	76,1	72,3	57,0	81,5	92,8	71,7	99,6

Torque / Efficiency [ Nm / daN ]



Available Through:  
**BORSERINI SRL**  
 Via N. Sauro, 1  
 I-23100 Sondrio SO  
 Ph. +39 0342 209200 E-mail: info@borserini.it